

NIKKISO NON-SEAL Pumps

Canned Motor Pumps.





NIKKISO NON-SEAL* Pumps.

NIKKISO began producing canned motor pumps in 1956, making it one of the first companies in the world to produce these pumps commercially. It continues to do so today. Originally developed for the nuclear industry, the canned motor pump has been developed further over the years and adapted to a wide range of industrial applications. Since its founding, NIKKISO has played a pioneering role in the product's development. For example, the E-Monitor is the most advanced system of its kind for monitoring the condition of bearings.

NIKKISO NON-SEAL Pumps.

The advantages at a glance.

1



Eco-friendly

NIKKISO's leak-free design prevents product loss and pollutant emission into the atmosphere. The best option for addressing worldwide concerns for the environment and increasingly stringent regulations.

2



Health and safety-oriented

NIKKISO NON-SEAL pumps' airtight design protects operators against exposure to substances that are dangerous to health. And the pumps are designed to handle explosive or flammable fluids, and other aggressive fluids.

3



Quiet and low-vibration

A fully encapsulated system without a motor fan or exposed bearings enables low-noise and low-vibration operation. Perfect alignment between the motor and pump also reduces system vibration significantly.

4



Unique E-Monitor

NIKKISO offers highly reliable canned motor pumps. In order to fit predictive maintenance programs, NIKKISO NON-SEAL pumps also have the E-Monitor feature for local bearing monitoring.

5



Small & compact, low space requirements

Pump and motor integration means space is used especially efficiently. With minimal base space requirements, set-up costs are reduced.

6



Simple installation and maintenance

Compact design combined with a low number of required components enables simple installation and maintenance. Feeler gauges and shims are no longer necessary. And since there is only one shaft, alignment is a thing of the past.

Markets.



Chemical industry

NIKKISO is one of the leading manufacturers in the sealless pump industry for conveying hot oil. NON-SEAL pumps are often used as transfer pumps for chemical fluids or for unloading rail vehicles.



Refineries

The applications for refineries include the conveying of catalysts for alkylation (sulfuric or hydrofluoric acid), natural gas condensates, benzene, acidic water, volatile hydrocarbons or liquified natural gas (LNG).



Energy utilities

In the energy sector, NIKKISO canned motor pumps are used as seal water pumps, in high-pressure condensate applications, and for nitrogen oxide suppression.



Reference applications for NIKKISO NON-SEAL Pumps.



Industry: Chemicals
Application:
 Conveyance of cooling medium
 in the liquid natural gas (LNG) industry
NIKKISO solution:
 – Pumps with liquid recirculation
 – Vertical design, 75 kW motor power

Industry: Chemicals
Application:
 High temperature
NIKKISO solution:
 – Pump with cooling jacket

Industry: Chemicals
Application: Unloading from
 tanks and rail vehicles in paint factories
NIKKISO solution:
 – Self-priming pumps

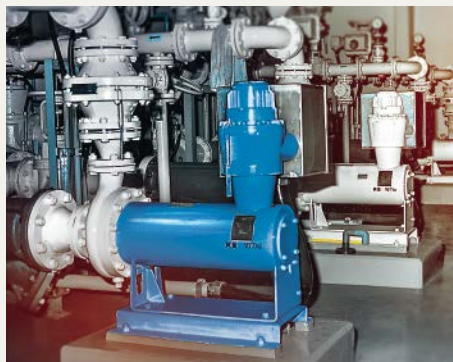

Industry: Chemicals
Application:
 Conveying liquids with a high
 melting point
NIKKISO solution:
 – Pump with heating jacket around the
 pump and motor housing

Industry: Chemicals
Application:
 Water treatment
NIKKISO solution:
 – Standard pump with special material
 (titanium) for housing and impeller

Industry: Chemicals
Application:
 Conveying chemicals
NIKKISO solution:
 – Pump in standard version

NIKKISO NON-SEAL Pumps.

NIKKISO NON-SEAL pumps are used in several different industries such as chemical, petrochemical, and petroleum refinery. For such applications, NIKKISO has developed pumps in accordance with ISO 2858*, API 685**, and other standards.

* DIN EN ISO 2858 :

- End-suction centrifugal pumps (rating 16 bar)
- Designation, nominal duty point and dimensions (ISO2858:1975)

** API STANDARD 685

- Sealless centrifugal pumps for petroleum, petrochemical, and gas industry process service

E-Monitor

The E-Monitor's LED display indicates relative axial and/or radial bearing wear during pump operation. Available as a local or remote display. LED directional display for simplified start-up.

Winding temperature monitoring

Satisfies most common directives or norms. Additionally, some options are available, e.g. bimetal (thermostats), Pt100, PTC, or thermocouple.

Embedded temperature monitoring unit

A sensor for measuring fluid temperature is embedded in the stator can.

Additional temperature monitoring (optional)

Bearings available in many different materials to meet the requirements of your process.

Second safety shell

According to requested standard. A pressure switch for leakage detection is also available.

Shaft protection sleeves and thrust washers

Shaft protection sleeves are available in a wide variety of surface treatments for customization in line with the respective liquid application. The thrust washers dampen high axial thrust under disruptive conditions and support hydraulic axial thrust balancing.

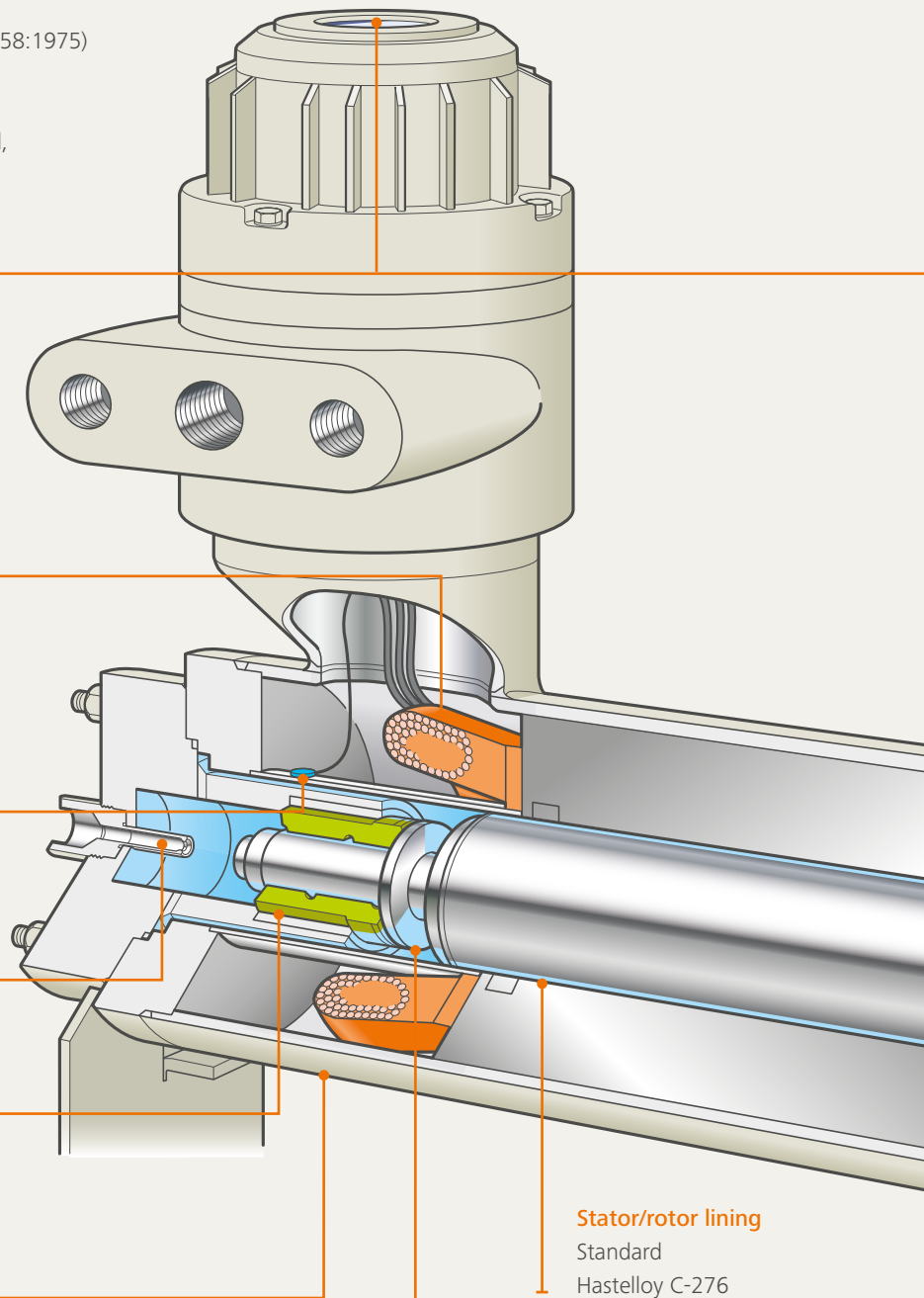

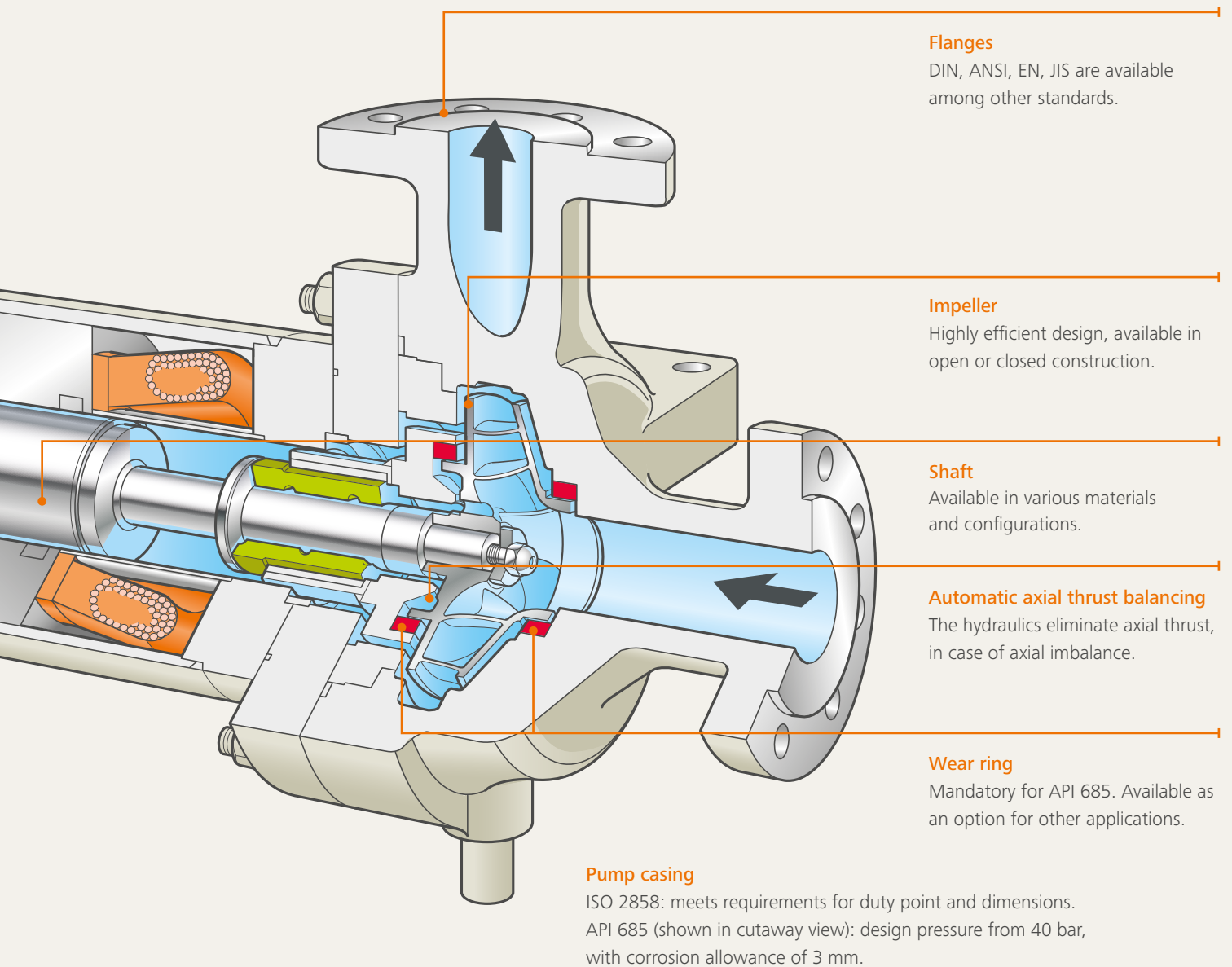
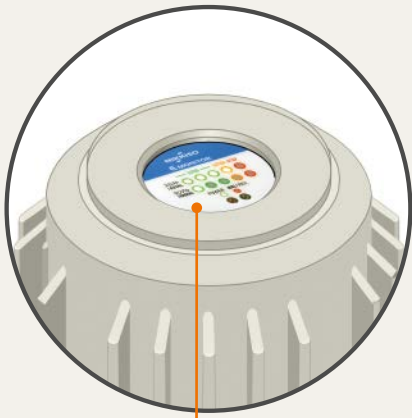

Flanges

DIN, ANSI, EN, JIS are available among other standards.

Impeller

Highly efficient design, available in open or closed construction.

Shaft

Available in various materials and configurations.

Automatic axial thrust balancing

The hydraulics eliminate axial thrust, in case of axial imbalance.

Wear ring

Mandatory for API 685. Available as an option for other applications.

Pump casing

ISO 2858: meets requirements for duty point and dimensions.
API 685 (shown in cutaway view): design pressure from 40 bar, with corrosion allowance of 3 mm.

Key features for reliability and safety.

Automatic axial thrust balancing

The hydrodynamic operating principle of a set of fixed and variable orifices enables an automatic axial thrust balancing to center the shaft between the bearings. This prevents wear to the bearings during normal operation. The interchangeable thrust washers and the thrust side of the bearings only come into contact with each other during start-up and under disruptive conditions, for example if the suction flow cuts off. Controlling the axial thrust on the impeller prevents the shaft position from influencing the motor cooling flow.

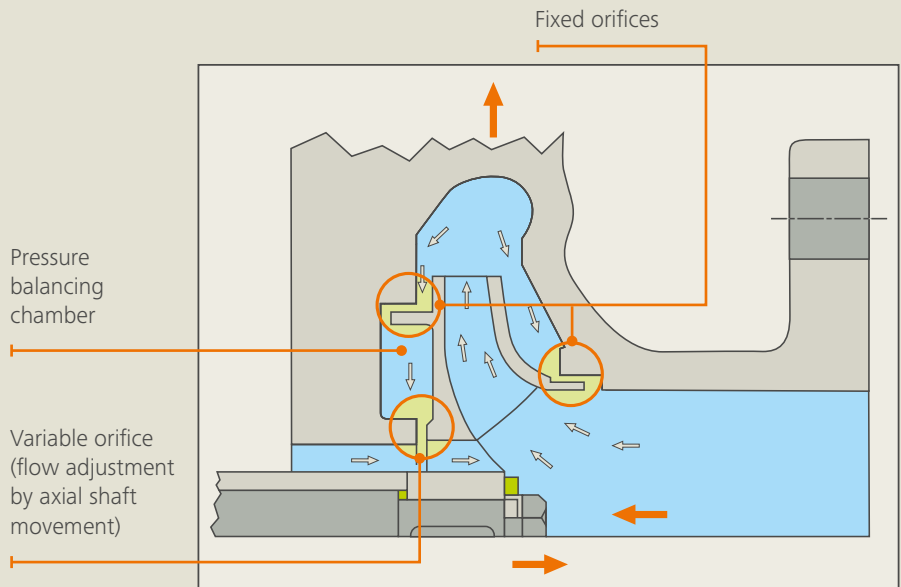

Reliable motors

- Protection against leakage through seal-welded and 100% leak-proof, corrosion-resistant linings. They ensure that the supplied medium does not come into contact with the stator windings or the core of the rotor.
- The complete outer side of the motor is encapsulated in a second leak-proof protective shell.
- Motor cooling and bearing lubrication by the working fluid circulating in the rotor chamber.
- The motor windings and insulation system are specially designed, developed, and implemented as an integral part of the pump so that the design's service life is equal to at least that of conventional air-cooled motors.
- Integrated temperature monitoring at stator winding indicates when to switch off the motor in case of overheating. Thermostats can also be provided.
- The working fluid absorbs heat from the stator winding and bearings, preventing the winding temperature from reaching unsuitably high temperatures. Cooling jackets enhance heat absorption from the stator winding. If cooling fluid cannot be provided, a ceramic insulated stator winding is another option.
- Integration of the canned motor in the pump ensures both environmental protection and occupational safety.
- All parts of the motor, including the pump, are designed for easy, and fast maintenance. This design minimizes the frequency and duration of expensive downtime.

E-Monitor

NIKKISO developed the E-Monitor to determine the wear condition of the bearings during pump operation. The position of the rotor is monitored while the pump is operating. The state-of-the-art bearing wear monitor can also be used for predictive maintenance.

Display:

- Separate displays for axial and radial bearing wear
- Wear of front or rear bearings
- Pump “ON”
- Display for rotating direction

Advantages:

- The directional display indicates whether or not the pump is rotating in the correct direction. No other tools are required.
- Since the E-Monitor receives its power supply via the motor’s terminal box, external wiring is not necessary.

E-Monitor operating principle

Bearing wear causes the rotor to slip from its proper position. Sensors integrated into the stator detect the actual, real-time position of the rotor in both the axial and radial directions. As soon as the rotor is not correctly positioned, sensors detect the change and display it on the E-Monitor. Any change in the status of the bearings is displayed to the operating personnel

on a simple and clearly arranged LED display. An LED that is illuminated in green indicates that the bearings are in good condition. An LED illuminated in yellow indicates that the pump should be checked at the next regular system shutdown. If the LED lights up in red, the pump should be immediately shut down and checked.

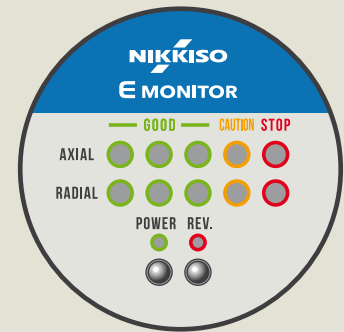

Display

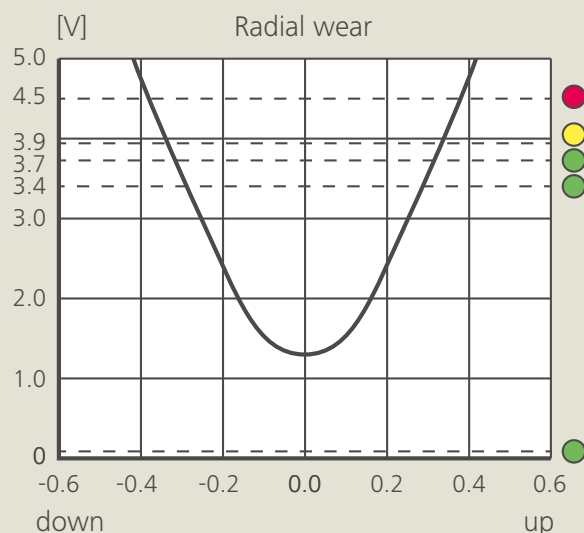
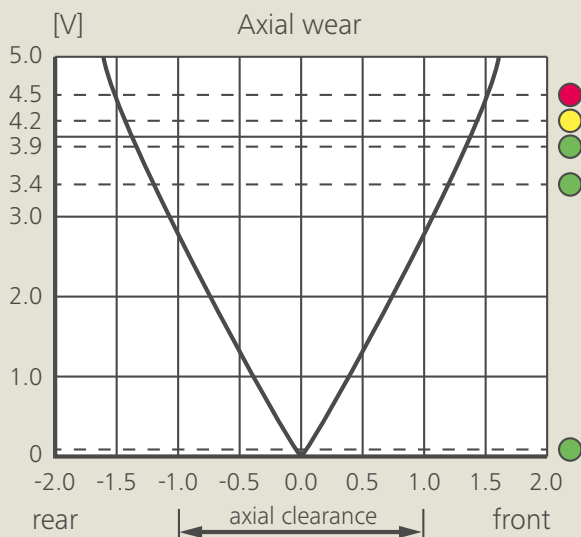

Key features for reliability and safety.

Modular bearings system

NIKKISO bearings are slide bearings. The materials used range from various carbon graphites and polytetrafluorethylene (PTFE) to silicon carbide. The use of CG93, a mixture of carbon and silicon carbide, increases protection against wear without compromising tenacity.

The bearings are liquid-lubricated and designed with a groove for an improved supply of lubricant.

Depending on the application, the shaft protection sleeves are either chromium-plated or finished with a hardened material.

The thrust washers (made of hardened material or chromium-plated) limit the movement of the shaft under disruptive conditions to reduce the risk of damage to the pump.

To simplify the installation process, identical front and rear bearings, shaft protection sleeves, and thrust washers are used.

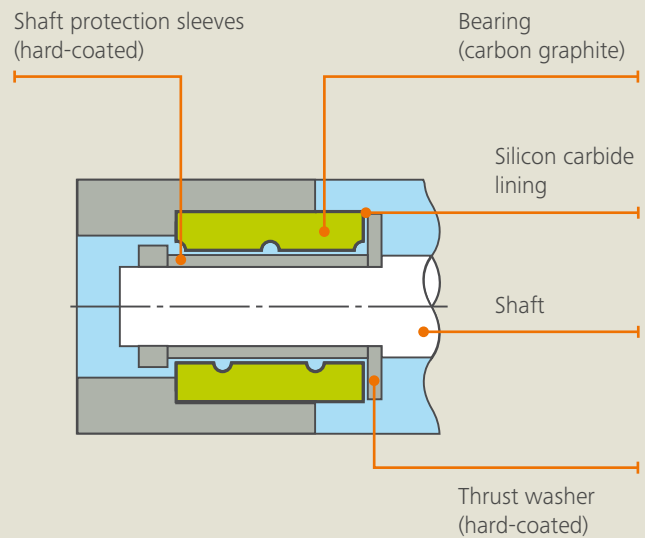



For a wide variety of requirements. NIKKISO NON-SEAL Pump Types.

Standard applications

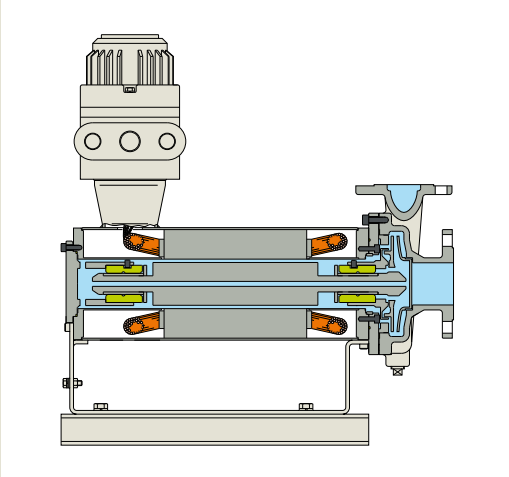

Type HN

Standard version

Suitable for a wide variety of clean, non-volatile liquids with moderate temperature.

Flow rate up to 780 m³/h
 Head up to 210 m (300 m at 60 Hz)
 Motor power up to 132 kW (200 kW without explosion protection)
 Temperature -60 to +200 °C
 Viscosity up to 80 cP

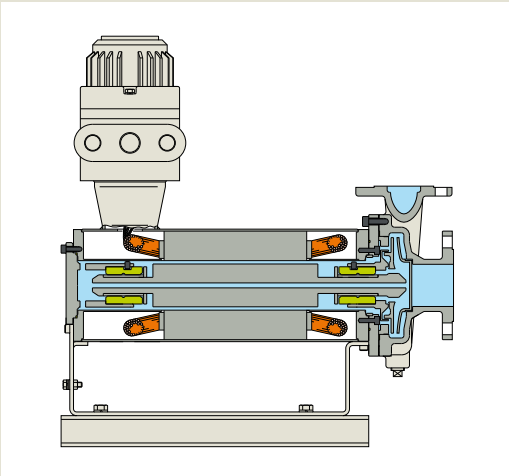

Type HV

High-viscosity liquids

Handles liquids with a viscosity from 80 cP up to 200 cP.

Flow rate up to 180 m³/h
 Head up to 200 m
 Motor power up to 44 kW
 Temperature -60 to +200 °C
 Viscosity up to 200 cP

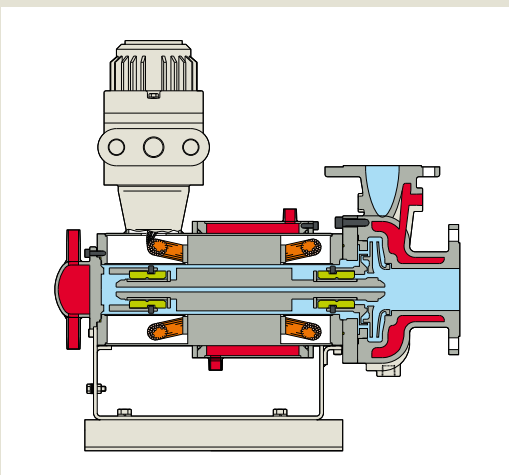

Type HB

Jacketed casing for liquids with high melting point

With heating jackets around the pump casing, the motor, and the rear bearing housing in order to keep a constant temperature up to 140 °C.

Flow rate up to 160 m³/h
 Head up to 200 m
 Motor power up to 22 kW
 Temperature -60 to +200 °C
 Viscosity up to 200 cP

High temperature applications

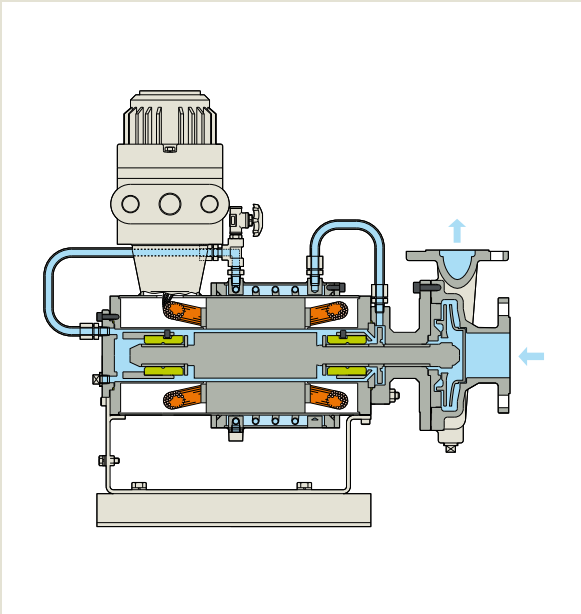

Type HT

With external cooling fluid

Specially designed to handle hot liquids. Process fluid is recirculated within the rotor chamber via an auxiliary impeller. A cooling jacket together with a coiled tube heat exchanger and a thermal isolation spacer are provided to maintain a suitable fluid temperature in the rotor chamber.

Flow rate up to 780 m³/h
 Head up to 210 m (300 m at 60 Hz)
 Motor power up to 132 kW
 Temperatures up to +400 °C
 Viscosity up to 200 cP

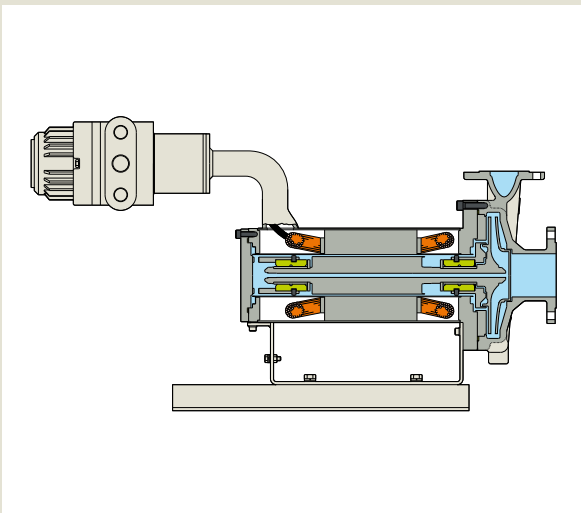

Type HX

Without external cooling fluid

The application of ceramic insulated wires allows the conveyance of liquids at high temperatures, where cooling media is not available nor desired.

Flow rate up to 200 m³/h
 Head up to 200 m
 Motor power up to 55 kW
 Temperatures up to +350 °C
 Viscosity up to 200 cP

Slurry applications

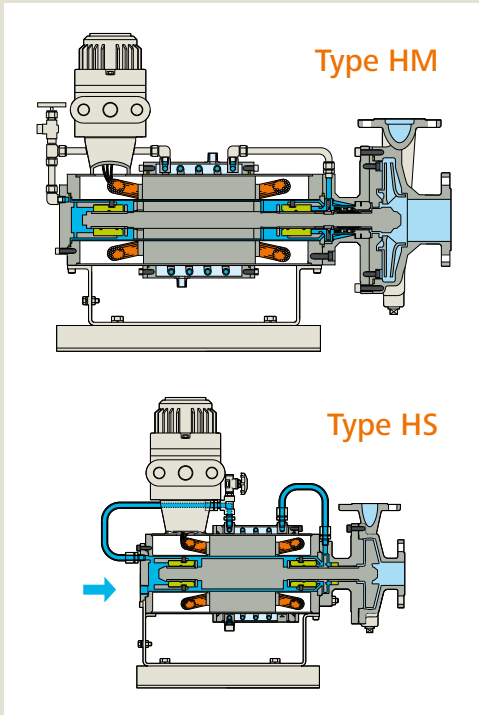

Types HM (mechanical seal) and HS (throttling bush)

Slurry handling

A clean flushing fluid compatible with the pumped fluid must be added. It is constantly circulated in the motor section for cooling and bearing lubrication and preventing the intrusion of solids or liquids with high vapor pressure into the rotor chamber. An auxiliary impeller is used for recirculation. An integrated heat exchanger, like type HT, dissipates the heat created by friction or current heat losses. In order to prevent as much flushing fluid as possible from entering into the process medium and to minimize their loss, the clearances between the motor and the pump are designed to be very narrow. Despite the required flush fluid (similar to conventional pumps with double seal), there is neither a shaft protrusion to be sealed nor any gaskets. Type HM is available with a shaft seal for reduced flushing rates. Type HS is equipped with a throttling bushing.

Flow rate up to 780 m³/h
 Head up to 300 m
 Motor power up to 200 kW
 Temperatures up to +400 °C
 Viscosity up to 500 cP

Applications for highly volatile fluids

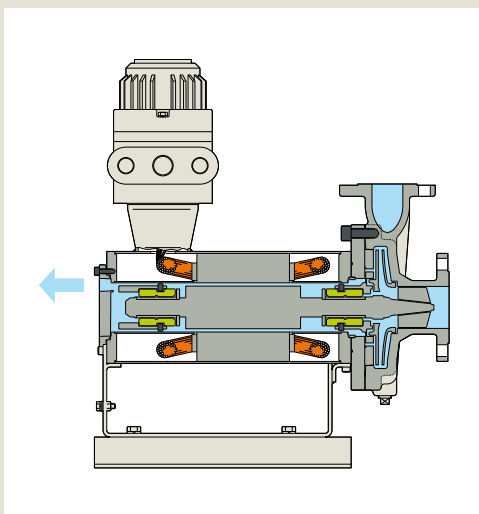

Type HQ

Reverse circulation

Designed for liquids with high vapour pressures (or steep vapour pressure curves), which would evaporate after absorbing heat from the motor side, upon returning to the impeller eye. With the HQ pumps, the liquid is evacuated from the motor side to the vapour zone of the suction tank. The reverse line (return line to suction tank) is throttled to maintain high pressure liquid within the motor side. Simultaneously, this reverse line serves as a vent line.

Flow rate up to 180 m³/h
 Head up to 200 m
 Motor power up to 44 kW
 Temperature -60 to +185 °C
 Viscosity up to 200 cP

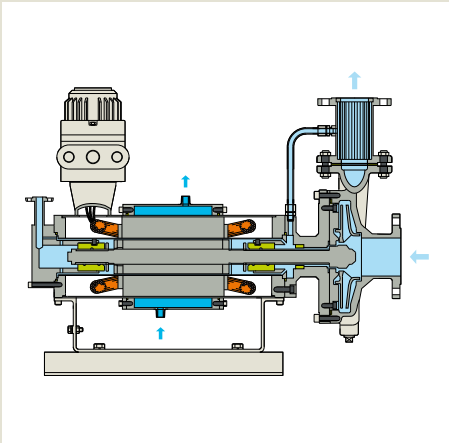

Type HR

Reverse circulation

Designed for fluids with extremely high vapor pressure (or very steep vapor pressure curves), type HR utilizes flow at full discharge pressure injected directly into the rotor chamber. The return line is throttled to maintain the liquid's high pressure within the motor and normally also serves as a vent line.

Flow rate up to 780 m³/h
 Head up to 210 m
 Motor power up to 132 kW
 Temperature -60 to +185 °C
 Viscosity up to 200 cP

Additional designs

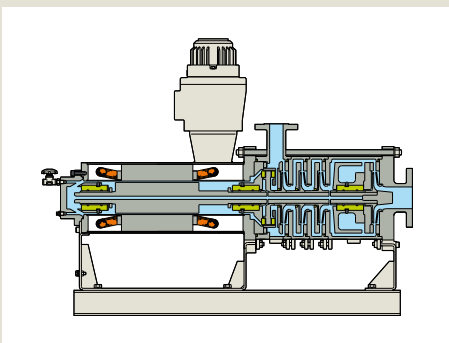

Multistage

Pumps with high head

Pumps for high pressure applications through three or more impellers.

Flow rate up to 120 m³/h
 Head up to 500 m
 Motor power up to 132 kW
 Temperature -30 to +150 °C
 Viscosity up to 140 cP

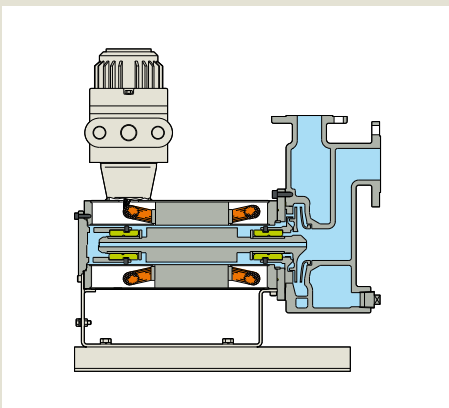

Type DN

Self-priming pump

Self-priming volute casing for suction lift applications. Eliminates the risk of clogged foot valves.

Flow rate up to 180 m³/h
 Head up to 70 m
 Motor power up to 45 kW
 Temperatures up to +170 °C
 Viscosity up to 200 cP
 Self-priming head (water +20 °C) up to 7 m

Accessories.



Sealing system

For slurry applications, pump types HM and HS need clean flushing fluids (backflushing) in order to prevent slurry from intruding into the rotor chamber. For these pumps, NIKKISO offers sealing systems that provide backflushing for cooling and bearing lubrication in the rotor chamber.



Inducer

Available for lower net positive suction head requirements. Equipped with long, helical blades, NIKKISO inducers significantly improve suction performance.



Mechanical bearing monitoring

Fully mechanical version for monitoring bearings that indicates axial and radial bearing wear. It can also help detect corrosion inside the motor.



Compatible for automation

NIKKISO provides connections in the terminal box for the remote signaling of both, axial and radial bearing wear. They are available to the distributed control system (DCS) through analog 4–20 mA or 0–5 V signals.



Protection systems

NIKKISO NON-SEAL pumps offer as an option dry-running protection and liquid level monitoring in order to prevent serious damages to the pumps.

- Load monitors measure the motor shaft power and automatically stop the pump in case of very low flow (or not at all) in the rotor chamber.
- Level indicators send warning signals when there is no fluid in the rotor chamber, cooling jacket, heat exchanger or vent pot.

NIKKISO NON-SEAL Pumps deliver the highest quality. As demonstrated by our certification.

<p>API:</p>  <p>NIKKISO pumps in accordance with API 685 are optionally available.</p>	<p>ATEX 2014/34/EU:</p>  <p>The pumps fulfill the guidelines for devices and protection systems for intended use in potentially explosive areas.</p>	<p>CE:</p>  <p>Certification in accordance with CE (“Conformité Européenne”) marking is standard for European customers; it is also available for non-European customers upon request.</p>
<p>ISO9001:2015:</p>  <p>Our quality management is certified in accordance with ISO9001:2015.</p>	<p>TR-CU and TR-CU-Ex:</p>  <p>The pumps are certified for the Eurasian Economic Union (EAEU).</p>	
<p>EN 80079-36 and 37:</p> <p>The pumps correspond to the European standards for non-electrical devices for use in potentially explosive areas.</p>	<p>EMC Directive 2004/108/EG:</p> <p>The pumps fulfill the requirements of the EMC Directive on the electromagnetic compatibility of electrically operated devices.</p>	<p>EN 60079-0/1/7 i:</p> <p>The pumps correspond to the European standards for explosion protection.</p>
<p>EN 60529:</p> <p>The pumps are protected by housing with protection class IP 65.</p>	<p>Machinery Directive 2006/42/EG:</p> <p>The pumps fulfill the uniform level of protection defined in the Machinery Directive for the prevention of accidents for machines and partly completed machinery.</p>	<p>German Technical Instructions on Air Quality Control (TA-Luft):</p> <p>The pumps fulfill the requirements of TA-Luft.</p>

At a glance.

Technical data.

Technical data

	Standard	Engineered
Max. flow rate	780 m ³ /h	1000 m ³ /h
Max. head	210 m single-stage, 425 m multistage	600 m
Fluid temperature range	-60 to +400 °C	-130 to +450 °C
Max. viscosity	200 cP	500 cP
Design pressure	Max. 40 bar (4 MPa)	Max. 200 bar (20 MPa)
Motor power range	0.4 to 132 kW	Up to 250 kW
Liquid end material	316SS, 304SS	Alloy 20, Hastelloy C/B* ¹ , titanium, zirconium, Monel * ² , etc.

*¹ HASTELLOY® is a registered trademark of Haynes International Inc.

*² MONEL® is a registered trademark of Huntington Alloys Corporation

Head-flow rate curves

50 Hz

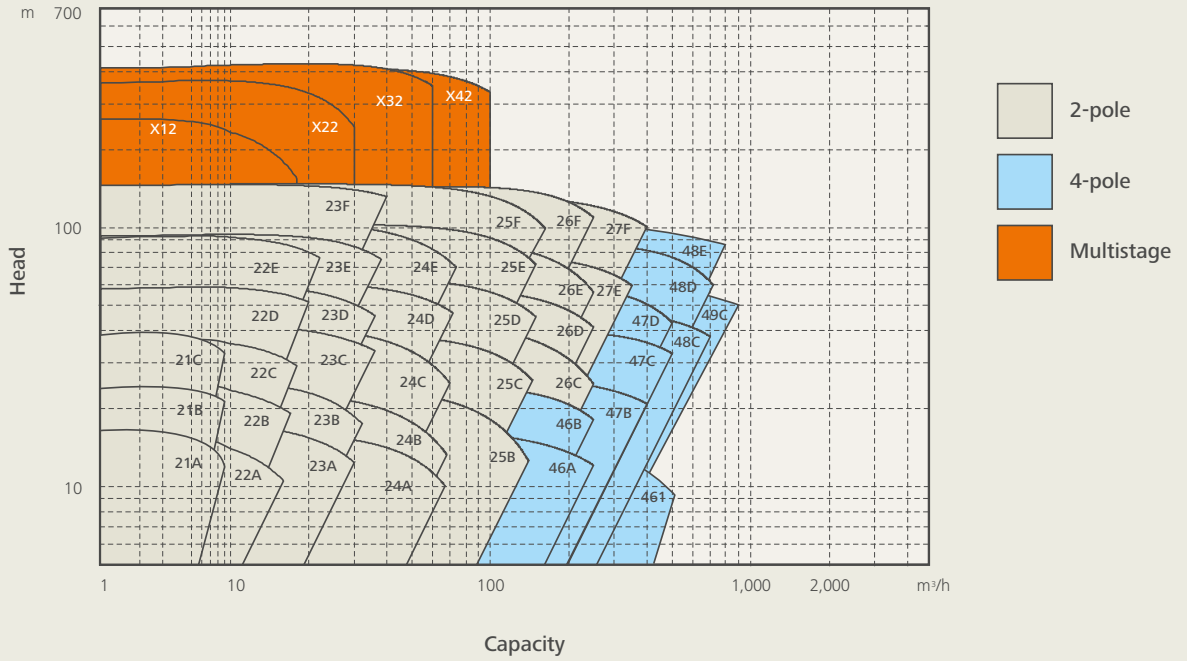

60 Hz

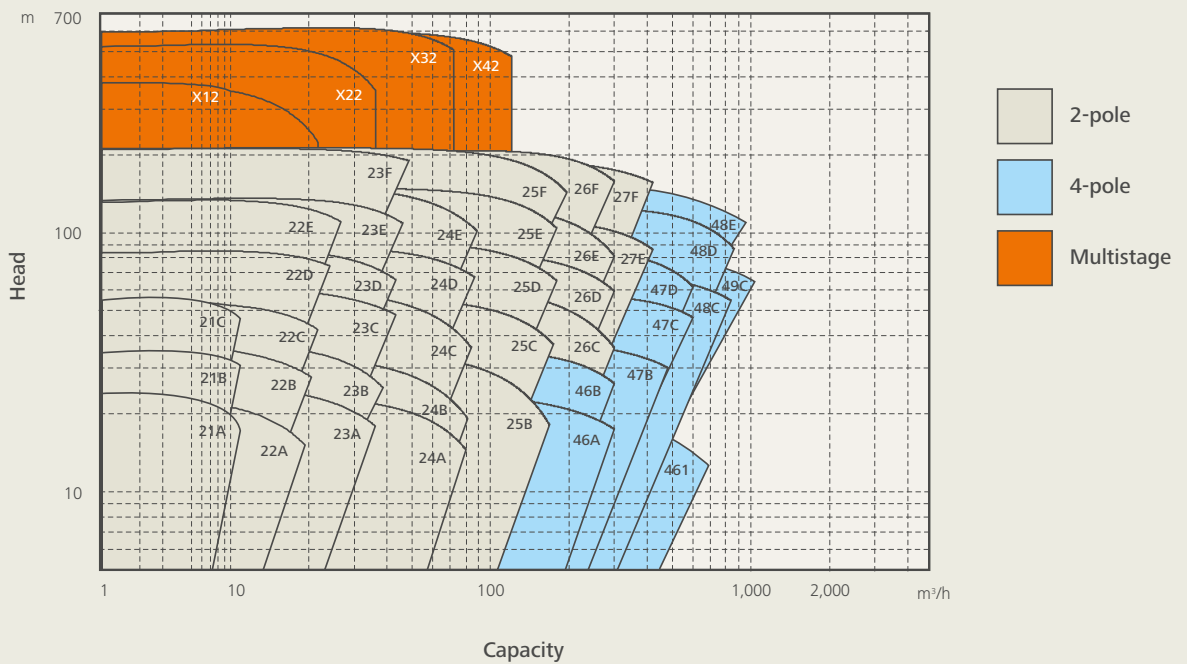

NIKKISO NON-SEAL Pumps in accordance with DIN EN ISO 2858.

DIN EN ISO 2858 is a European standard for centrifugal pumps that primarily defines the dimensions of pumps and sets a predefined standard nominal output (Viso, Hiso). The newly developed series in accordance with this standard offers operators a safe and reliable alternative to conventional centrifugal pumps for the conveyance of aggressive, toxic, or explosive media.

Technical data (ISO 2858 pumps)

Flow rate	Max. 80 m ³ /h
Head	Max. 90 m
Motor power	2-pole, max. 27.5 kW
Temperature	-60 °C to +400 °C
Pressure level	PN 16

Certification: ATEX Ex de IIC T5 – T1 (IECEx Ex de IIC T5-T1)

NIKKISO's response to the chemical industry requirements for standardized and interchangeable pumps are models that comply with DIN EN ISO 2858. Thus, conventional centrifugal pumps can be exchanged and plant safety can be increased without modifying the isometry of the existing piping.

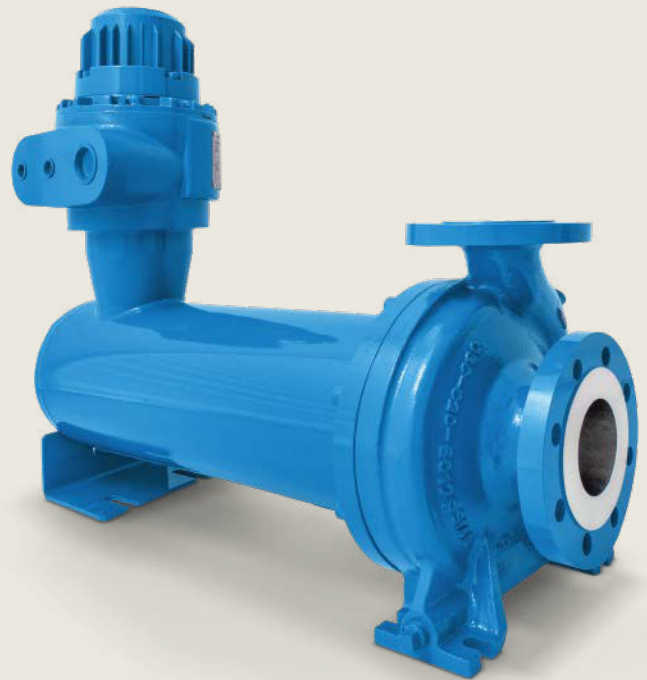

Hydraulic coverage chart

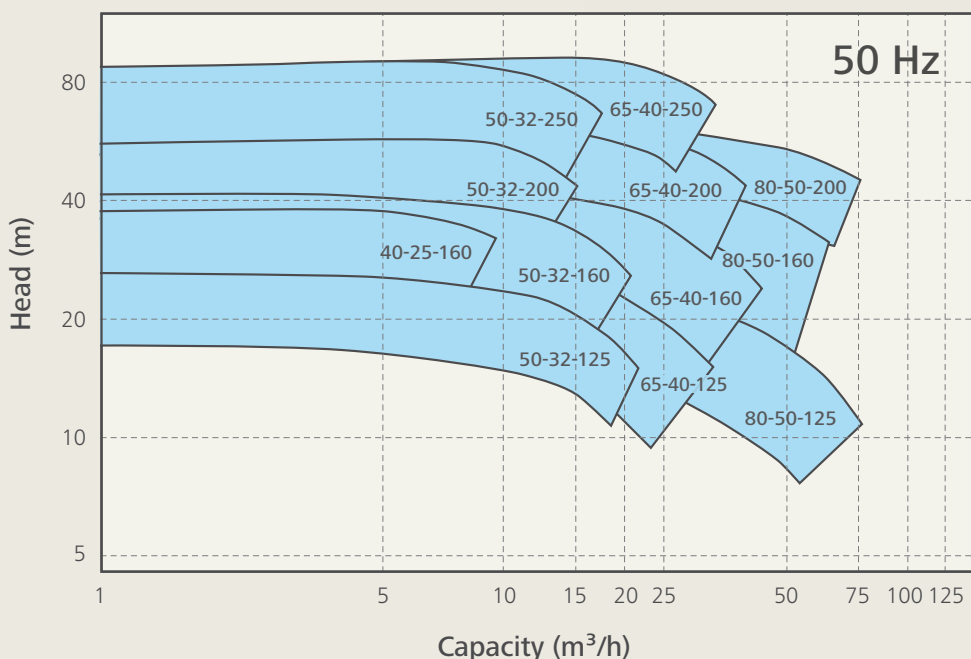

This chart shows the 12 different pump sizes for NIKKISO canned motor pumps, which conform to DIN EN ISO 2858.

The complete ISO series and the entire NIKKISO NON-SEAL pump portfolio are distributed around the globe by the LEWA NIKKISO network.

Creating Fluid Solutions.

Driven by our commitment, our trendsetting products and innovative technologies have set benchmarks for diaphragm pumps and metering systems for over 70 years. We solve complex tasks from a single source. That ranges from custom pump design, basic and system engineering, global project management, and pretesting to commissioning and maintenance on site. Our consistent drive always to develop the best solutions for the customer provides you with a competitive advantage and visible added value.

Your local representative:



LEWA GmbH
Ulmer Str. 10
71229 Leonberg
Germany

www.lewa.com