

LEWA ecoflow[®]

The custom-made metering pumps.

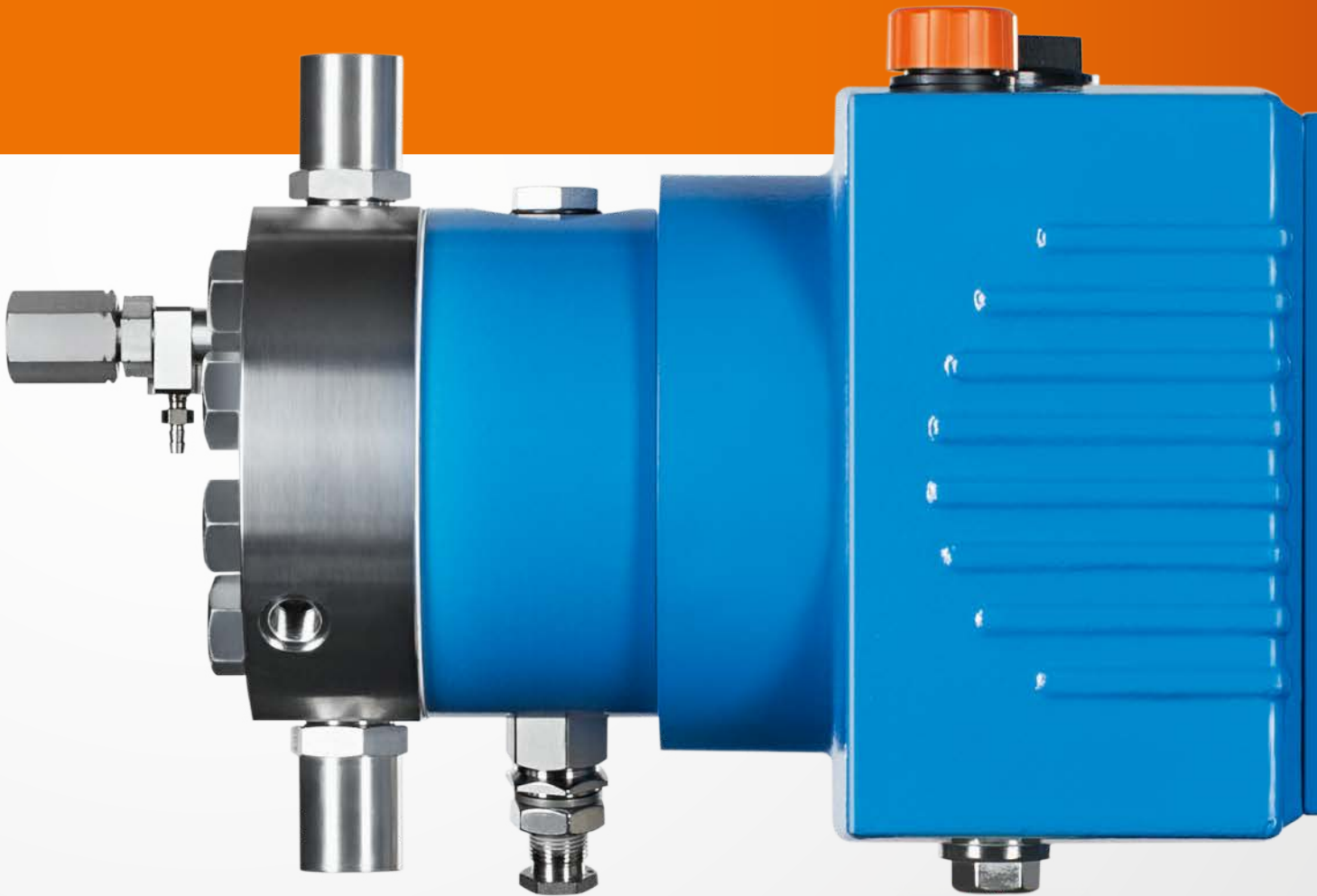

Contents

03	Advantages at a glance
04	Modular system
06	Areas of application
12	Pump heads
19	Valves
20	Drive units
24	Technology
26	Options
28	Technical data
30	Packages and systems

The custom-made metering pump.

LEWA ecoflow is an extensive modular system for diaphragm and packed plunger metering pumps. It combines eight drive sizes with six different pump head types. Your expectation is our expectation – with this modular system, its many options, and our special solutions, we can meet even the toughest of customer requirements. LEWA ecoflow is considered the most advanced metering pump product line in the world and is constantly being refined and undergoing further development.



LEWA ecoflow.

The advantages at a glance.

Reliable components are one of the keys to safe processes. LEWA ecoflow pumps are based on the robust technology that LEWA is renowned for. As a result, they are also easily able to fulfill the strict safety requirements of API 675 (American Petroleum Institute). The pumps use key components from LEWA's proven range – like the PTFE sandwich diaphragm with diaphragm monitoring, the patented DPS diaphragm protection system and flow efficient check valves.

1

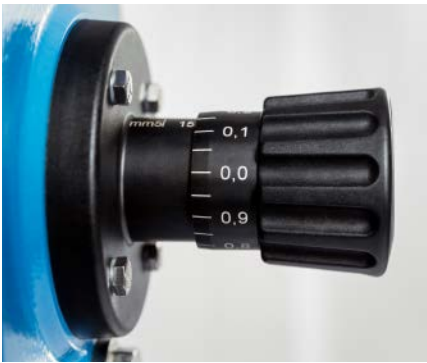

Highest metering accuracy

LEWA metering pumps provide gentle, precise conveyance with reproducibility as required – even at high pressures.

2

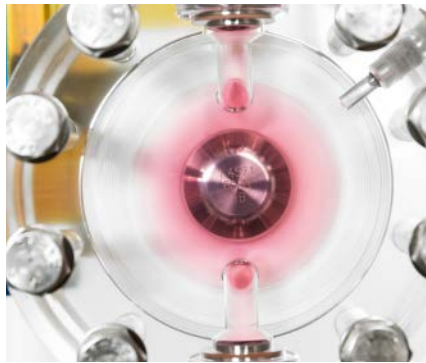

Hermetically tight

LEWA diaphragm pumps work without dynamic seals, due to their design. This permits a hermetically tight working area. There are no external emissions and contamination of the fluid is impossible.

3



Maximum operational safety

Secure against misuse and against impermissible operating states, resulting in outstanding system availability. A monitoring system indicates possible diaphragm damage immediately. The pump can still be operated for a limited time.

4



Custom-made solutions

The modular system permits a wide variety of solution options. LEWA specializes in demanding requirements and is continually working with you to extend the set of solutions.

5



Lowest lifetime costs

LEWA develops pumps for long service life. The assemblies run for decades in continuous operation. Our pumps achieve the highest efficiency of any pump technology.

6



Worldwide service

LEWA is globally organized. Spare parts and service are quickly available worldwide.

For unlimited possibilities. The modular system.

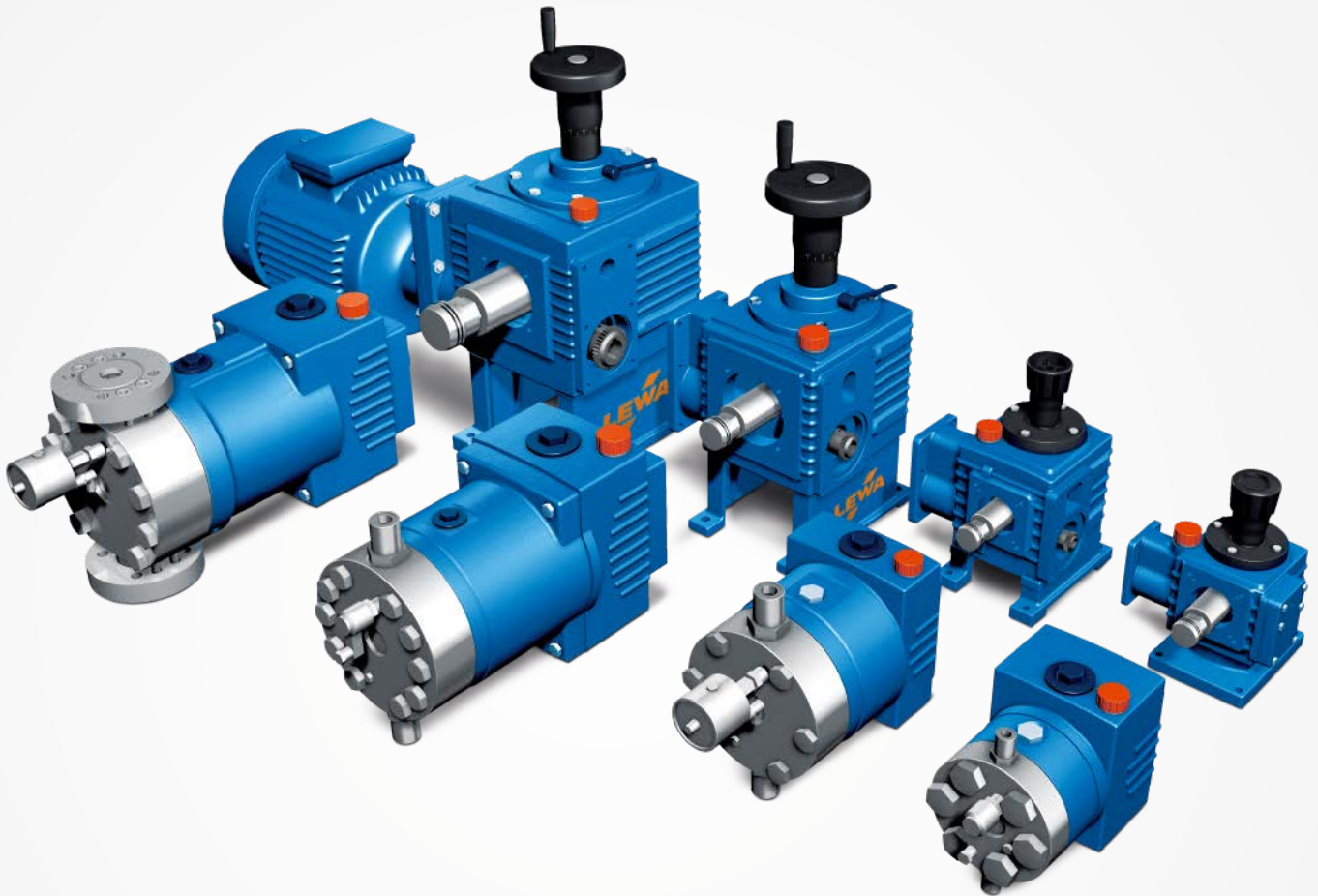

LEWA ecoflow metering pumps can be used to solve a wide variety of tasks. The large number of variants is not only due to the possible combinations of drives and pump heads.

The multiple arrangement of identical and different drives – in segment or boxer design – is also possible without problems. This permits volume flows to be handled in a variable manner and different material flows can be conveyed or metered at certain ratios (recipe metering). Even the widest variety of materials and surfaces (such as hygienic requirements) can be selected to match the fluid conveyed. For extreme fluid and environmental conditions (such as temperatures), special designs are also available.

And LEWA is always extending the portfolio with new developments and refinements.

For individual requirements. Schematic diagram of the modular system.

Scope of performance and application areas

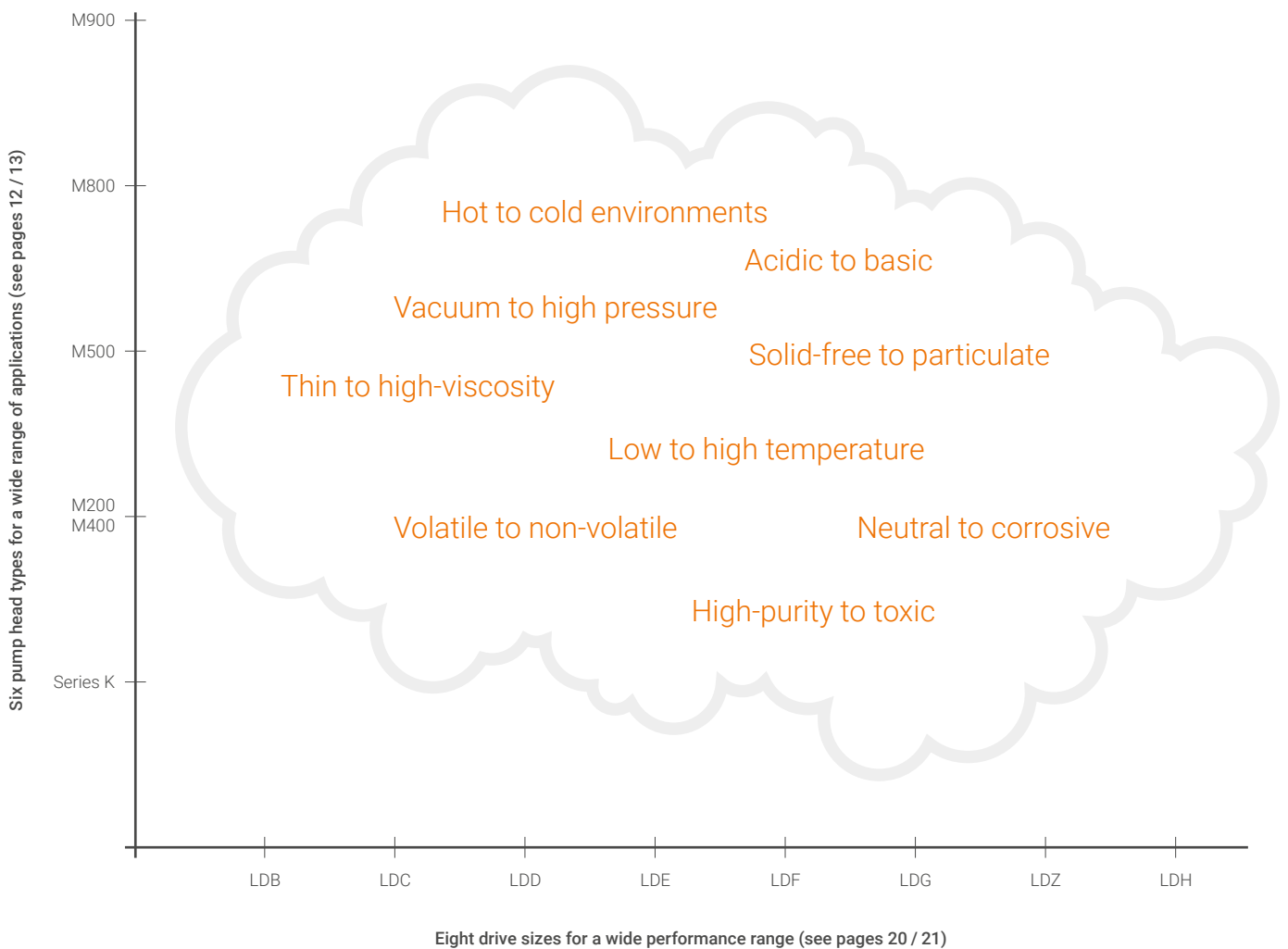



Chemical industry

Hermetically tight LEWA ecoflow pumps for use up to 1,200 bar are the first choice for the manufacture of chemical intermediate and end products



Petrochemistry

The most important processes in petrochemistry are cracking and reforming processes. For over 70 years, we have delivered robust pumps for these applications.



Oil and gas industry

The oil and gas industry has special requirements that make qualified equipment and experienced suppliers essential. We offer EPC companies, operators, and end customers a complete line of high-end diaphragm, packed plunger pumps and even complete systems and modules.



Energy utilities

We support processes in power generation, transport, distribution, and storage with our products and know-how. LEWA systems are even used for the manufacture of solar panels.



Food and beverages

Process integrity, recipe constancy, and product reliability are basic prerequisites in food technology.

Hygienic aspects and cleanability play a central role. Contamination of the process media has to be avoided. That's a case for LEWA.



Pharma and biotechnology

Whenever sterile fluids are reliably conveyed or materials purified, validated pumps and systems from LEWA are almost certainly in use.

For a wide variety of requirements.
The LEWA ecoflow pump heads.



Series
M900

**The universal choice
for fluids of any kind**

Innovative diaphragm pump head of the latest generation for maximum operational reliability. The patented LEWA DPS technology also enables a suction capacity that is globally unique in the field of hydraulically actuated diaphragm pumps.



Series
M800

**The compact choice
for highest pressures**

The special geometry of the diaphragm fixation system enables the use of PTFE diaphragms in pressure ranges up to 800 bar and thus results in a very compact shape.



Series

M500

**The proven choice
for high volume flows**

Universal diaphragm pump head for high flows. Proven, durable, reliable and with patented diaphragm position control.



Series

M200 M400

**The extreme choice
for high temperatures**

M200/M400 pump heads have a metal diaphragm and are designed for high temperatures and pressures up to 1,200 bar. Also suitable when a high degree of permeation resistance is required.



Series

K

**The simple choice
for unproblematic fluids**

Packed plunger pump heads are preferred for simple, unproblematic fluids, and represent a high-quality solution at an attractive purchase price.

For fluids of any kind. Universal M900 diaphragm pump heads.

The M900 pump head is an innovative diaphragm pump head of the latest generation, with PTFE sandwich diaphragm for maximum operational reliability.

As a further development to the M500 series, it is just as durable and proven, however has more safety reserves, especially when starting up the pump. The patented LEWA DPS technology also enables a suction capacity that is globally unique in the field of hydraulically actuated diaphragm pumps.

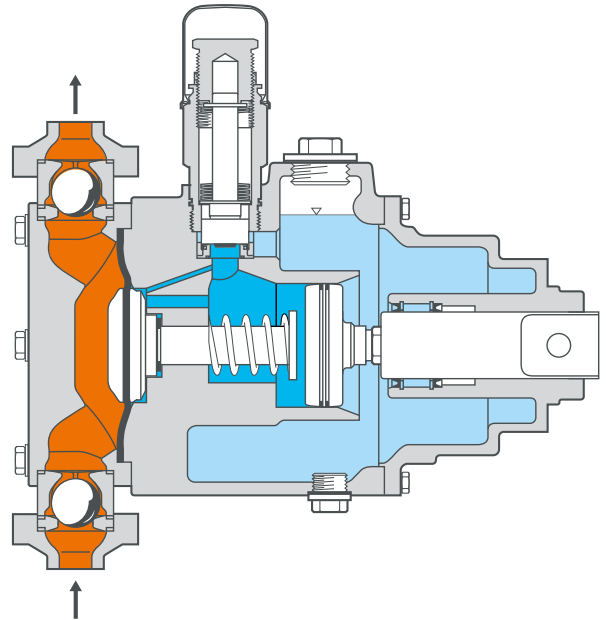

Technical data

Discharge pressure up to 500 bar

Flow rate up to 6 m³/h per pump head

Temperatures from -20 to +150 °C

Viscosity up to 100,000 mPa·s

1.4401/1.4404 (AISI 316/316L),
special materials

Can be installed on all ecoflow drive units

Outstanding advantages

Globally unique suction lift capability

Suitable for vacuum extraction

Simple, reliable start-up, even under
extreme conditions

Patented DPS diaphragm protection system

Very low maintenance costs and
long service intervals

Insensitive to particles in the fluid

Dry run safe

Integrated pressure relief valve

For highest pressures. Compact M800 diaphragm pump heads.

The M800 pump head is a diaphragm pump head with PTFE sandwich diaphragm

The special geometry of the diaphragm fixation system enables the use of PTFE diaphragms in pressure ranges up to 800 bar and thus results in a very compact shape. Very economical solution in the range of high pressures, especially in comparison with pump heads with metal diaphragms.

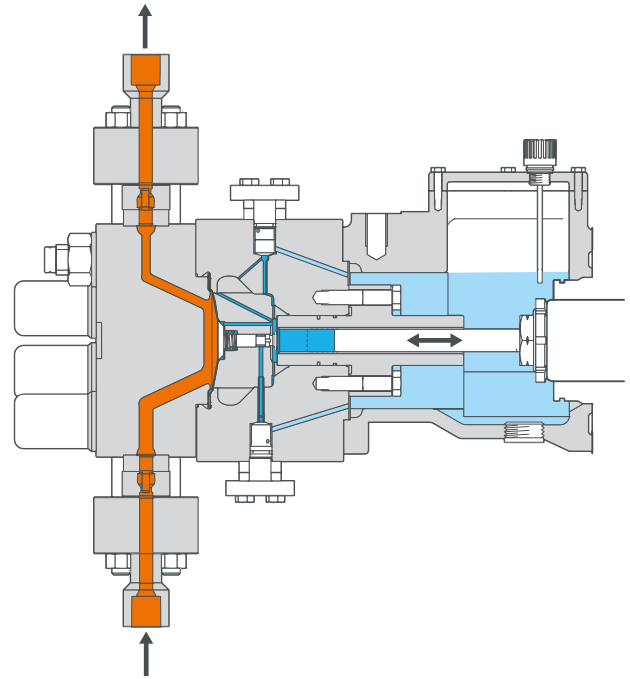

Technical data

Discharge pressure up to 800 bar

Flow rate up to 1.1 m³/h per pump head

Temperatures from -10 to +60 °C

Viscosity up to 100,000 mPa·s

1.4313 (ASTM UNS S41500) or 1.4462 (ASTM UNS S31803) (Duplex)

Can be installed on all ecoflow drive units ≥ LDF

Outstanding advantages

Extremely high operating pressures possible

Compact design and smallest possible use of materials by using PTFE diaphragms even in the high-pressure range (and so having smaller outer diameters in comparison with metal diaphragm pump heads)

Insensitive to particles in the fluid

Dry run safe

Integrated pressure relief valve

For high volume flows. Proven M500 diaphragm pump heads.

The M500 diaphragm pump head with PTFE sandwich diaphragm is universally applicable. It is perfect for high flow rates.

The M500 has been in successful use for decades. Its advantages are robustness, reliability, and its patented diaphragm position control.

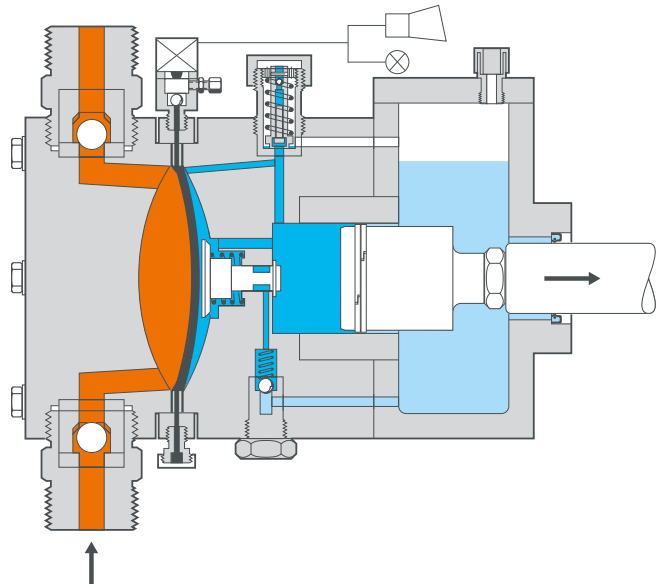

Technical data

Discharge pressure up to 350 bar

Flow rate up to 19 m³/h per pump head

Temperatures from -50 to +150 °C

Viscosity up to 100,000 mPa·s

1.4401/1.4404 (AISI 316/316L),
plastics PVC or PVDF, special materials

Metal pump heads (1.4401/1.4404 (AISI
316/316L)): can be installed on all ecoflow
drive units ≥ LDE

Plastic pump heads (PVC/PVDF/PTFE): can
be installed on all ecoflow drive units ≤ LDE

Outstanding advantages

High suction capacity due to diaphragm
position control

Very low maintenance costs and long
service intervals

Suitable for high volume flows

Insensitive to particles in the fluid

Dry run safe

Integrated pressure relief valve

For high temperatures. M200/M400 diaphragm pump heads for extreme requirements.

M200/M400 pump heads with metal diaphragms are selected for highest pressures and high temperatures. They are also suitable when a high degree of permeation resistance is required.

The diaphragm works between two contour plates, limiting the deflection of the diaphragm and providing an extreme level of operational reliability. The diaphragm monitoring system offers a plus for safety by immediately displaying the damage of a diaphragm layer.

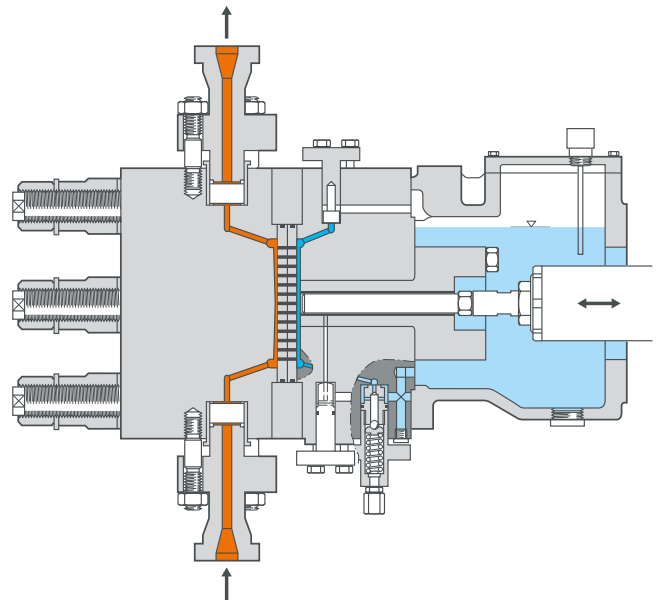

Technical data

Discharge pressure up to 1,200 bar

Flow rate up to 1.1 m³/h (M200)
or 0.8 m³/h (M400) per pump head

Temperatures from -40 to +200 °C

Viscosity up to 500 mPa·s

1.4401/1.4404 (AISI 316/316L),
special materials

M200 can be installed on all ecoflow
drive units ≤ LDE

M400 can be installed on all ecoflow
drive units ≥ LDF

Outstanding advantages

Extremely high operating pressures possible

Extremely high operating temperatures
possible

Diffusion-tight metal diaphragm

Dry run safe

Integrated pressure relief valve

For unproblematic fluids.

The simple packed plunger pump heads of Series K.

Packed plunger pump heads are an alternative for simple fluids

With this design the metered fluid is displaced directly by the plunger, i. e., the plunger and packing are wetted. A high degree of operational reliability is reached through the high quality plunger material and seal design.

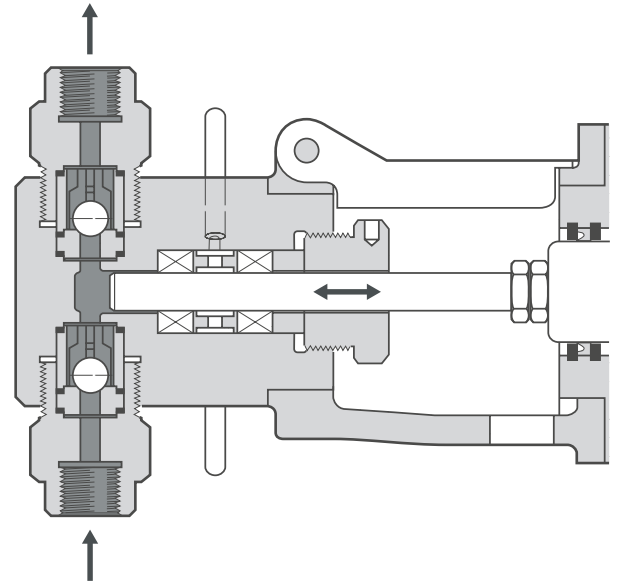

Technical data

Discharge pressure up to 500 bar

Flow rate up to 9 m³/h per pump head

Temperatures from -70 to +400 °C

Viscosity up to 1,500,000 mPa·s

1.4401/1.4404 (AISI 316/316L),
special materials

Can be installed on all ecoflow
drive units ≤ LDE

Outstanding advantages

Cost-effective introductory solution for simple metering tasks

Extremely high operating temperatures possible

Plungers made of different materials

High availability due to movable plunger connection and a specific selection of materials for every application

Specific options

Plunger packing with purging possibility

For a wide variety of requirements. A wide selection of valves.

Precision valves are a must for the perfect function of metering pumps. For LEWA ecoflow, we offer a wide variety of valve variants for any possible requirement.

The significant criteria when selecting the right valve are: Physical and chemical properties of the fluid, temperature of the fluid, discharge pressure, and pump stroke frequency. For suspensions, the properties of the solid particles should also be noted.

Ball valve (standard valves for nominal diameters up to 15 mm)

Beneficial for flow

High functional reliability, even for contaminated fluids or suspensions

Depending on nominal diameter, can be used for stroke frequencies up to 350 min⁻¹

Spring-loaded

– To increase closing force for viscous fluids

– To create a positive differential pressure between the suction and pressure sides

Disc valve (standard valves for nominal diameters 25 mm and over)

For large volume flows

Suitable for high viscosity

For extreme stroke frequencies (up to 400 min⁻¹)

With insert ring for slurries

Cone valve (standard valves for nominal diameters 25 mm and over)

Standard valve for large volume flows

Combines the advantages of ball and disc valves

Suitable for high stroke frequencies (up to 250 min⁻¹)

Suspension variant available

Custom valves

Double ball valve (standard valves for nominal diameters 10 mm and smaller)

Particularly well-suited for low-viscosity fluids (such as liquefied gases)

For high tightness and metering accuracy

Suspension valves (available for nominal diameters up to 85 mm)

Thanks to flow-beneficial design, suitable for suspensions

Valve seats available with soft material insert or of hard metal to reduce wear

Hardened valves or valves in hard metal, oxide ceramic, silicon nitride

For very low wear

Other variants on request

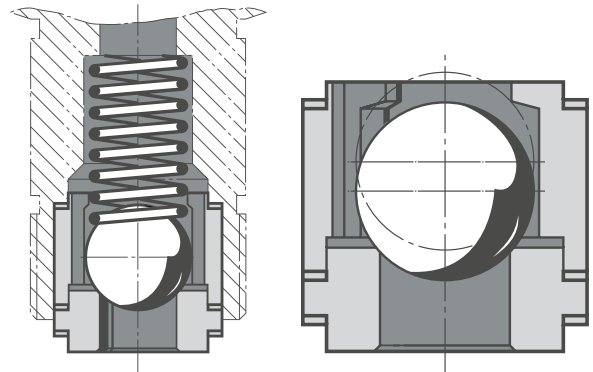

Ball valve

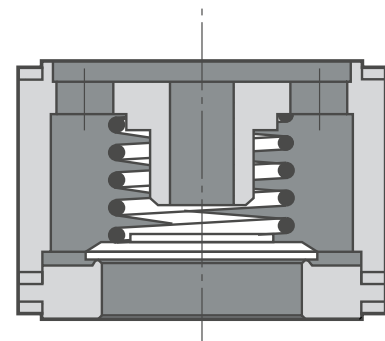

Disc valve

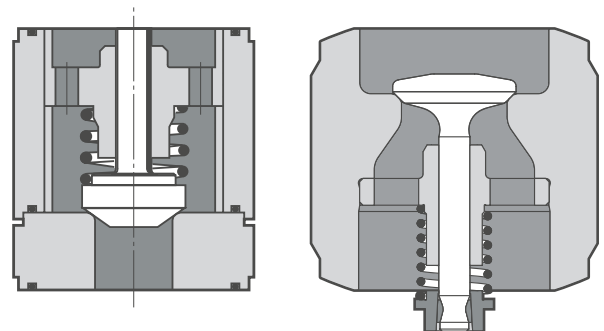

Cone valve

Hanging cone valve

For individual requirements. The drive unit sizes.

Our pumps cover a range from 0.1 l/h to 19 m³/h per pump head.
If the range needs to be extended, we offer multiplex or boxer design.



1



2

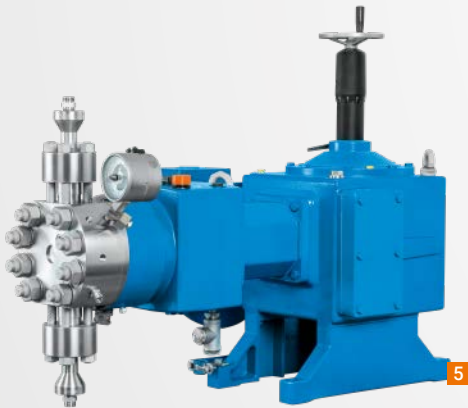

5



6

LDB

1

LDC

2

LDD

3

LDE

4

max. hydraulic power
(drive unit)

0.14 kW

max. hydraulic power
(drive unit)

0.36 kW

max. hydraulic power
(drive unit)

1.0 kW

max. hydraulic power
(drive unit)

2.9 kW



3



4

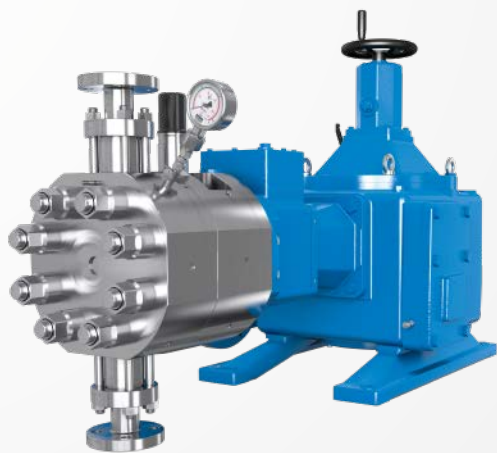

7



8

LDF

5

LDG/LDGB

6

LDZ

7

LDH/LDHB

8

max. hydraulic power
(drive unit)

6.5 kW

max. hydraulic power
(drive unit)

9.5 kW/
9.0 kW

max. hydraulic power
(drive unit)

16.5 kW

max. hydraulic power
(drive unit)

23kW/
38 kW

For small or large metering quantities. Drives, stroke adjustment, speed.

The right drive unit is selected from the LD series depending on the metering performance and control range needed

With eight sizes and different transmission ratios, a wide performance range can be covered. The drives can also be operated with constant stroke length or with stroke adjustment. This can be done manually, electrically, or pneumatically. The metering flow can also optionally be regulated continuously by speed using a frequency converter.

Function stroke adjustment

A variable eccentric can be used to adjust stroke length and therefore the metering flow very exactly over a wide range. With the variable eccentric drive, the drive torque is transmitted directly from the worm gear through the hollow shaft (1) to the eccentric wheel (2). By axially offsetting the sliding shaft (3), the eccentric can be adjusted radially. The stroke length of the crankshaft changes correspondingly.

Outstanding advantages

- _____ All sizes can be combined nearly arbitrarily
- _____ Exact, reproducible metering flow adjustment using stroke length (with a variable eccentric) and speed (with a frequency converter)
- _____ Wide control range 1:100 for flexible adjustment to different metering tasks
- _____ High overload safety
- _____ Also suitable for pure conveyance tasks
- _____ Also suitable for recipe metering
- _____ Very long service life due to solid overall design and high wear resistance
- _____ Simple service and maintenance
- _____ Very low maintenance costs and long service intervals
- _____ Common oil bath: LEWA ecoflow multiple pumps need no radial shaft seals between the elements

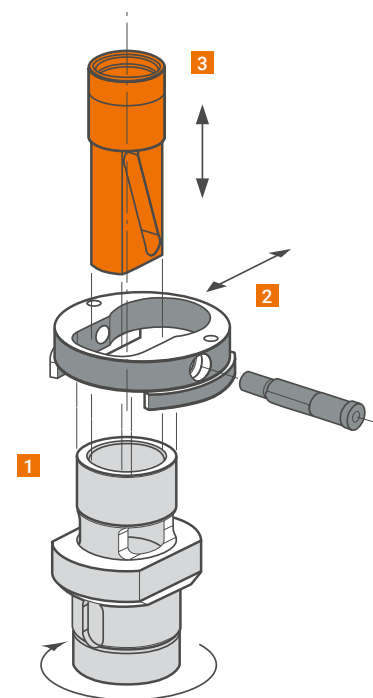
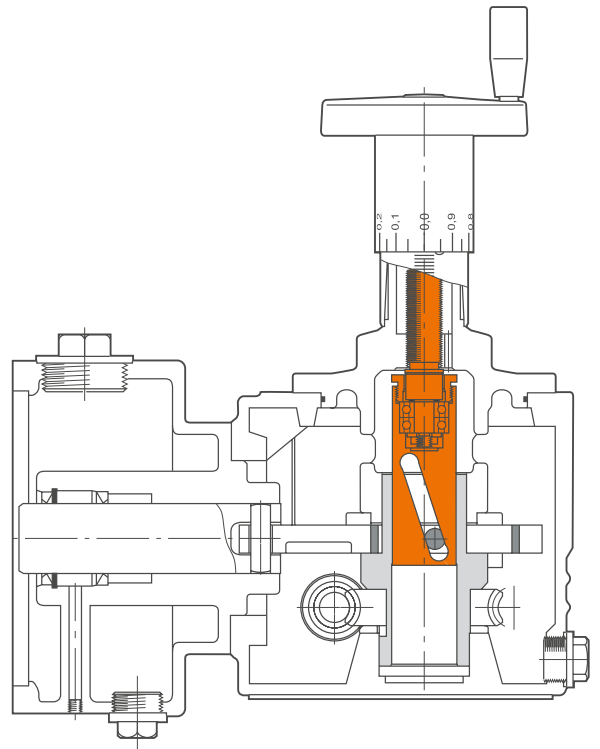

Specific options

Drive unit variants

As single drive unit with space-saving vertically installed motor

Multiple drive units that can be combined with identical or different output, to reduce pulsation, for recipe metering, or for high flow rates

Boxer design with double, quadruple, or sextuple pumps

Special material nodular cast iron GGG EN-JS1025 for very low ambient temperatures

Stroke adjustment variants

Electrical stroke adjustment

- Integrated end position and overload protection

- Response through potentiometer or 0/4 to 20 mA signal, bus

- Protection class is IP 67

- Position regulators: Controllable with 0/4 to 20 mA signals or Profibus DP

- Explosion protection

Pneumatic stroke adjustment

- Standard controller 0.2 up to 1 bar

- Control and response using 0/4 to 20 mA signal

- Protection class up to IP 54

- Protection class IP 65 optional

- Explosion protection EExiallCT6

Frequency converter for continuous regulation through speed

Drive variants

Standard motors with IEC or NEMA connections

Pneumatic drive

Diesel assemblies

Special drives of all kinds

Servo motor (LEWA intellidrive)

With or without explosion protection

Tried and true controllers, e. g. for proportional or batch metering, PLC

You can find a technical animation of the functionality here:



For tightness and safety. The LEWA ecoflow technology.

LEWA ecoflow is a hydraulically actuated metering diaphragm pump. The design principle ensures that the diaphragm of the pump head always works in the defined range.

Diaphragm pumps are used when leak tightness and operational reliability are in demand. Especially for fluids that are hazardous, abrasive, environmentally harmful, or sensitive. To keep the load on the diaphragm as low as possible, it is hydraulically actuated in the LEWA ecoflow. In combination with the DPS (Diaphragm Protection System), a long diaphragm service life can be guaranteed.

Low-wear valves for a variety of tasks

Operational reliability and service life are decisively dependent on valve quality. The valve design is therefore adapted to the specific application.

The right material for any fluid

The standard material is stainless steel 1.4401/1.4404 (AISI 316/316L). Material options of different metals and plastics are possible.

Minimum dead space, short dwell times

By optimizing the design of the pump head, the clearance volume in the working chamber can be kept low. The fluid flow is designed to ensure the problem-free execution of flushing and drying procedures.

Diaphragm monitoring system: For reliable status indication

The standard diaphragm monitoring system reliably shows the status of the diaphragm. Production can be stopped without danger in any case. The indication is realized via a pressure signal.

Pressure limiting valve

A pressure limiting valve in the hydraulic part of the pump prevents any overload situations in the pump. It can be individually adjusted in the LEWA ecoflow.

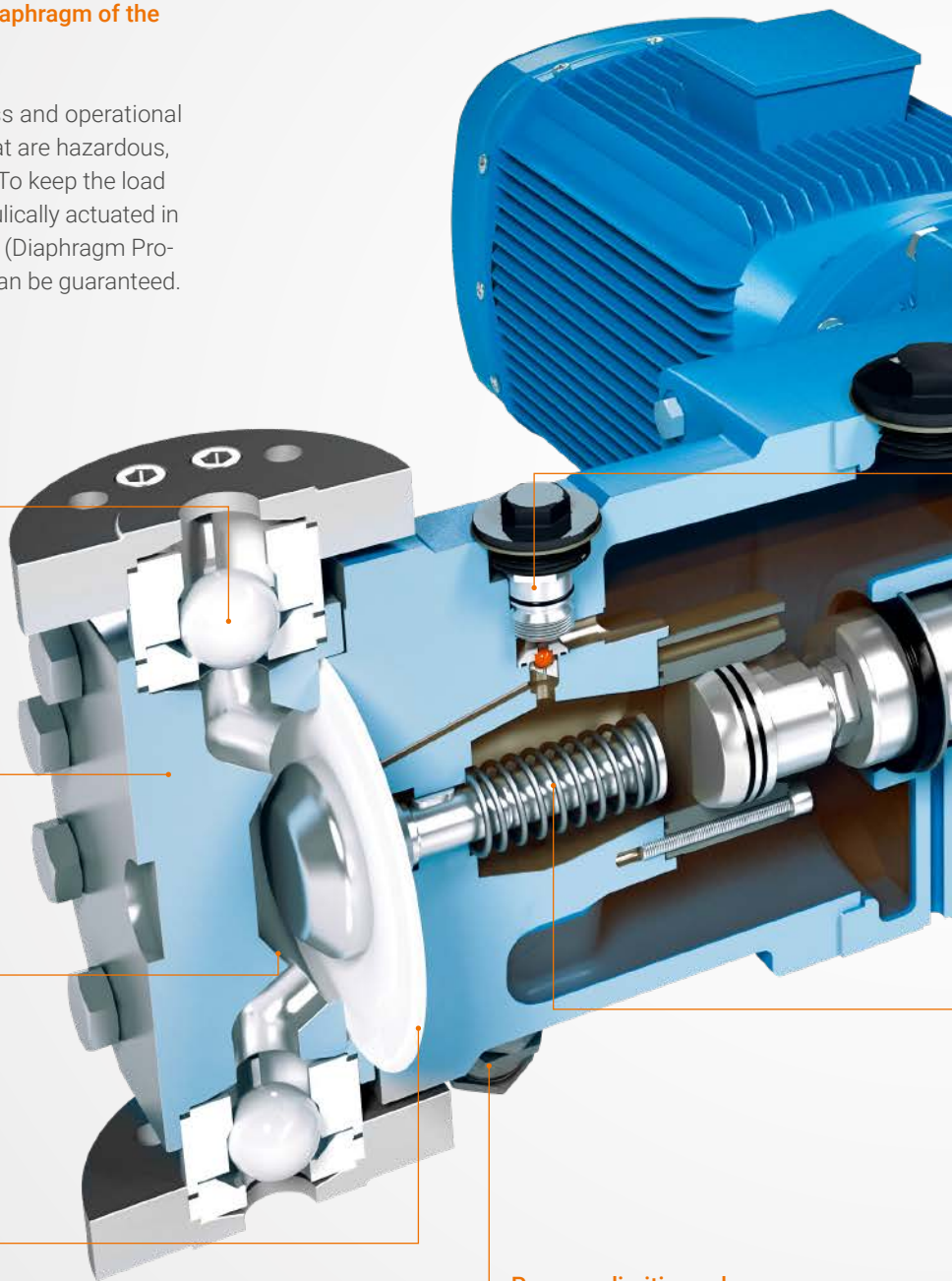

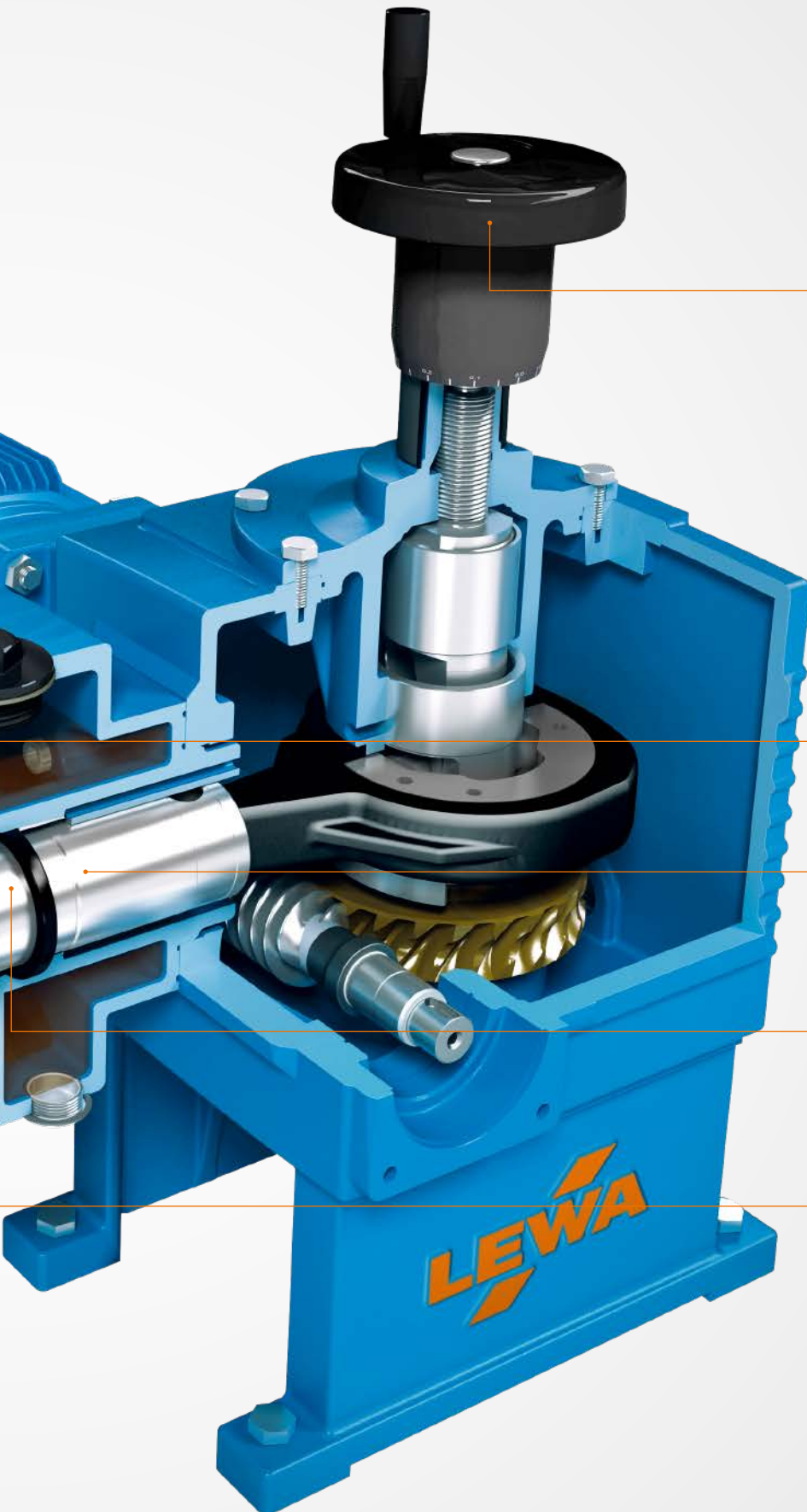
**High metering accuracy, gentle conveyance**

Metering pumps offer high metering accuracy and gentle conveyance, are stroke adjustable (manually, electrically, or pneumatically), and can also be adjusted in stroke frequency using a frequency converter. The reproducibility of settings is better than $\pm 1\%$.

Hydraulic control

The hydraulic valve ensures stable, precise operating conditions.

Lubrication

All moving parts run with immersion bath lubrication in oil

Separation of hydraulic and drive oil

This separation permits optimum adaptation to environmental influences as well as the requirements of the fluid and the process

Simple, reliable start-up

The diaphragm protection system ensures problem-free start-ups even under unfavorable background conditions

You can find a technical animation of the functionality here:



For the optimum configuration. Overview options.

Instrumentation, control, and monitoring

Integration of the pump into the process control systems for control, regulation, and condition monitoring

Diagnostic connection for the online readout of measurement data from the pump head and drive

Diaphragm monitoring systems to spec with pressure switches, manometers, contact manometers

Pump head designs

Special materials by customer request, for example 2.4610, titanium, plastics

Diverse connection geometries

CIP and SIP capability

Hygienic design

Heating and cooling jacket

Fully heated pump heads (including valves) for melting

Remote head design for extreme temperatures of -60°C up to +500°C

Accessories

Pulsation damper

Safety valve

Pressure retaining valve

Flow meter

Base plate

Collecting pipe

External safety valves to secure the system

External pressure retention valves for differential pressure generation



At a glance. Technical data.

Performance overview LEWA ecoflow

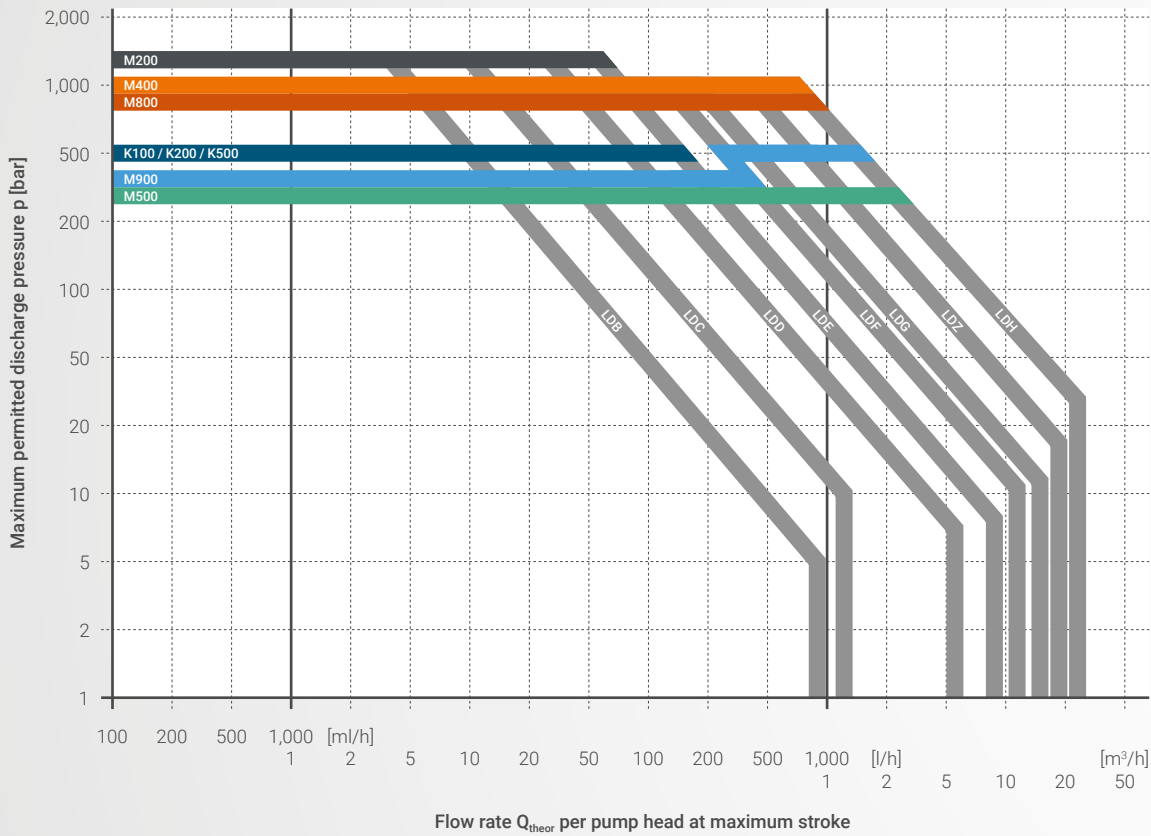

Performance overview to determine drive unit size. The characteristics apply to a single pump. Flow rate specifications per pump head.

Technical data for pump heads

	Pump head M500	Pump head M900	Pump head M800	Pump head M200	Pump head M400	Pump head K
Max. discharge pressure [in bar]	350	500	800	1,200	1,200	500
Max. flow rate [in m ³ /h]	19	6	1.1	1.1	0.8	9
Temperatures [in °C]	-50/+150	-20/+150	-10/+60	-40/+200	-40/+200	-70/+400
Max. viscosity [in mPa·s]	100,000	100,000	100,000	500	500	1,500,000
Applicable	on all ecoflow drive units ≥ LDE	on all ecoflow drive units	on all ecoflow drive units ≥ LDF	on all ecoflow drive units ≤ LDE	on all ecoflow drive units ≥ LDF	on all ecoflow drive units ≤ LDE

Assembly dimensions

in mm	Type LDB	Type LDC	Type LDD	Type LDE	Type LDF	Type LDG	Type LDGB	Type LDZ	Type LDH	Type LDHB
L	400	450	700	800	1,130	1,300	2,100	1,700	2,100	3,200
W	400	500	750	900	900	1,300	1,300	1,700	1,800	1,800
ΔW	185	220	280	350	430	490	490	700	717	717
H	260	320	610	690	940	1,000	1,000	1,140	1,500	1,500

The dimensional specifications differ depending on the pump head installed.

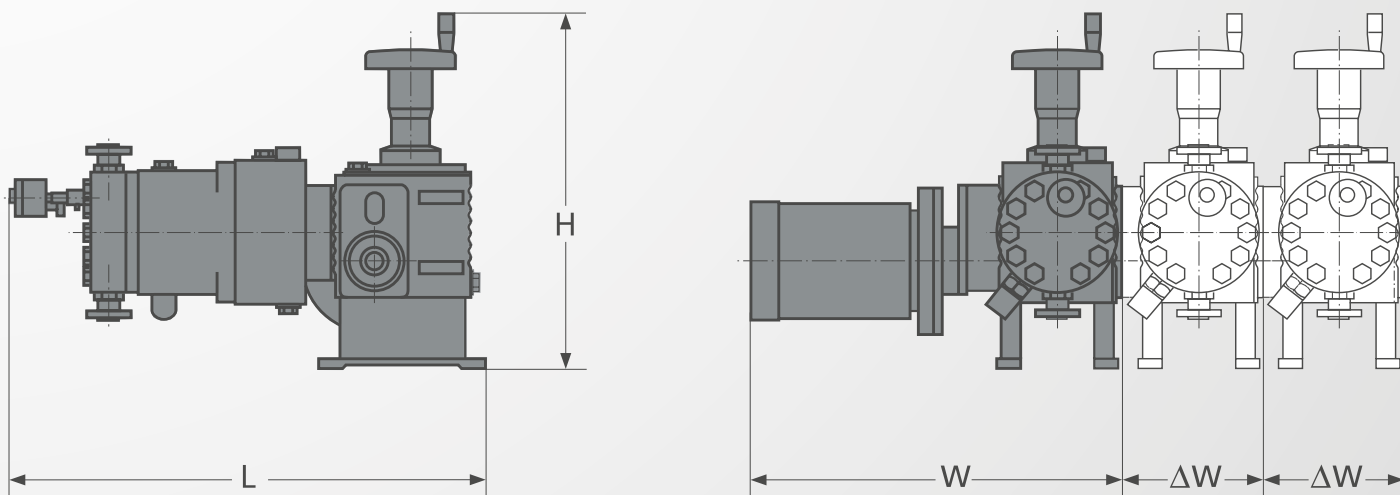

Complete solutions from a single source. LEWA packages and systems.

LEWA also offers solutions that go beyond individual metering pumps. For decades, we have built customer-specific systems, skids, and packages. Our service ranges from engineering to commissioning – including custom system controllers, process visualization, operational data collection, and external interfaces to the process control system.

We guarantee the optimum implementation of your requirements with our knowledge of intelligent process control and the controller and regulation technology needed to achieve it.

The basis is the competent selection and combination of system components and their characteristics. As our basic component, we prefer to use LEWA ecoflow metering diaphragm pumps.

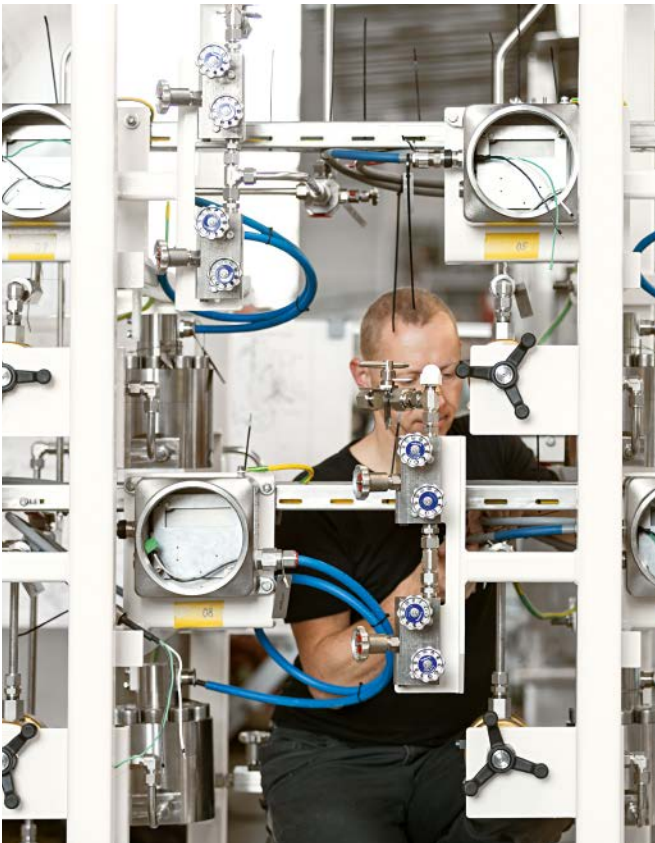

Each process has specific requirements. LEWA's experts tailor all components carefully to each other and bring in valuable industry know-how.

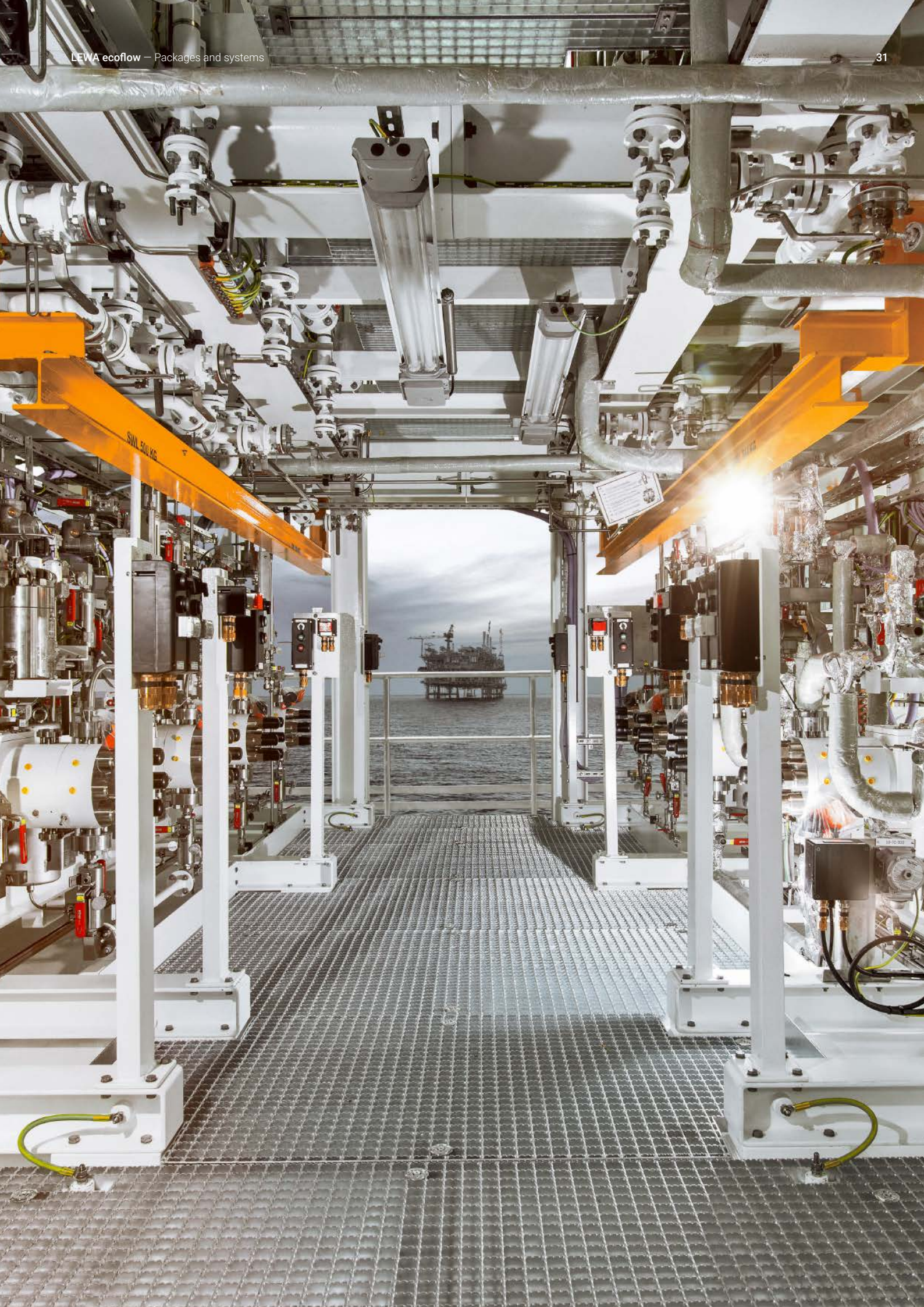

Creating Fluid Solutions. For more value created.



Technical consulting

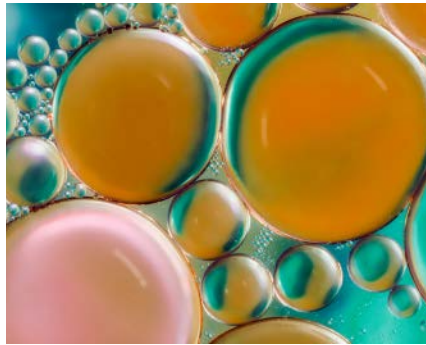

Fluid and process engineering tests



Lifecycle concepts and energy optimization

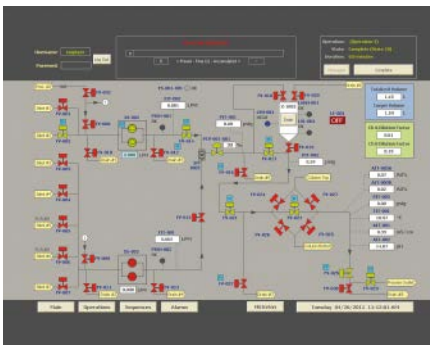

Process automation



Pulsation studies and pipeline calculations



System layout and integration



Creative development and refinements



Commissioning and maintenance service



Spare part and service concepts

Creating Fluid Solutions.

Driven by our commitment, our trendsetting products and innovative technologies have set benchmarks for diaphragm pumps and metering systems for over 70 years. We solve complex tasks from a single source. That ranges from custom pump design, basic and system engineering, global project management, and pretesting to commissioning and maintenance on site. Our consistent drive always to develop the best solutions for the customer provides you with a competitive advantage and visible added value.

LEWA GmbH

Ulmer Str. 10
71229 Leonberg
Germany

www.lewa.com

■ Part of Atlas Copco Group

