

LEWA ecodos®

The mechanically actuated
diaphragm metering pump.



Contents

03	Advantages at a glance
04	Areas of application
08	Pump heads
10	Technology
12	Sanitary and hygienic design
14	Designs, options, accessories
16	Technical data
18	Packages and systems

The ideal diaphragm metering pump in the low-pressure range. LEWA ecodos is a safe, reliable and efficient diaphragm metering pump with mechanical diaphragm actuation that provides many options.

It is suitable for virtually all metering and pumping tasks in the low-pressure range up to 20 bar. Its product spectrum ranges from 0.4 l/h to 1,500 l/h per pump head. Its multiplex capability makes additional areas of application such as low-pulsation conveying, recipe metering and mixing jobs possible. LEWA ecodos meets the stringent requirements for production of food and beverages as well as pharmaceuticals in the sanitary and hygienic designs, respectively. This ensures it fulfills both aseptic and hygienic specifications with high levels of reliability and efficiency.



LEWA ecodos.

The advantages at a glance.

1



Hermetically tight

LEWA diaphragm pumps work without dynamic seals, due to their design. This permits a hermetically tight working area. There are no external emissions and contamination of the fluid is impossible.

2

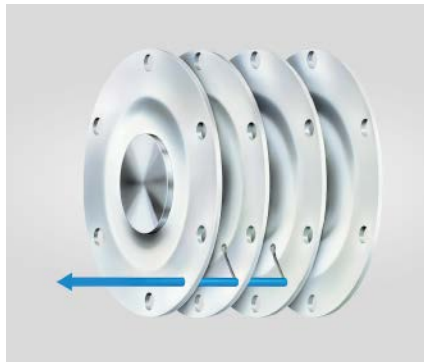

Maximum operational safety

The 4-layer PTFE sandwich diaphragm is not only extremely stable and durable. It is also monitored continuously during operation using the diaphragm monitoring system.

3



Exact metering setting

Even with pressures up to 20 bar, LEWA ecodos has a precise flow rate adjustment of $\pm 1\%$. The option of adjusting the pump using the stroke length and/or rotational speed makes it possible to achieve an exact, extensive adjustment range of up to 1:50.

4



Multiple design

With 6 output ratings and different material variants as well as adapted accessories, the diaphragm metering pump is suitable for virtually any pumping task in the low-pressure range.

5



Mechanically actuated

No hydraulic oil is used in the pump as a result of the mechanical actuation. This means the conveyed fluid cannot become contaminated. This is particularly relevant for pharmaceutical applications.

6

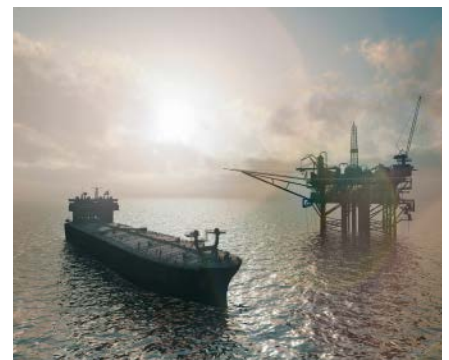

Worldwide service

LEWA is globally organized. Spare parts and service are quickly available worldwide.

Areas of application.

LEWA ecodos is the pump for high demands at low pressures. It fulfills customer requirements in a wide variety of application fields thanks to its adaptability.



Production of personal care products with LEWA ecodos sanitary for easy and thorough pump head cleaning



LEWA ecodos is hygienic for the stringent requirements of the pharmaceutical industry, such as the feed of fluids for extrusion or spray distribution during the production of active ingredients and tablet production



Metering sensitive liquids such as enzymes, vitamins or flavoring agents with LEWA ecodos sanitary



Adding additives such as colorants
in the chemical industry



Gentle metering of high-viscosity liquids during
the production of biofuels, for example



Proportional mixing of liquid components
for the production of detergents

LEWA ecodos meters everything, whether emulsions or slurries, bases or acids, paints or varnishes, detergents or solvents, grease or oils, hazardous or poisonous liquids, with maximum precision, safety and reliability.

For a wide variety of requirements. LEWA ecodos pump heads.

The LEWA ecodos series provides pump heads for all types of fluids. They are made of stainless steel or non-metallic materials. Two special designs are available for applications that require hygienic design.



Stainless steel pump head*

For industrial or sanitary applications

Technical data:

- Discharge pressure up to 20 bar
- Flow rate up to 1,500 l/h per pump head
- Temperatures from -10 to +80 °C

Outstanding advantages:

- Stainless steel design with DIN or ANSI connections
- Available as a sanitary design: wetted parts RA < 0.5µm, mechanically polished
- Triclamp or alternative sterile connections
- Suitable for Ex zone 1 (II 2 G)

* 1.4401/1.4404 (AISI 316/316L)



Non-metallic pump head (PVC/PVDF/PTFE-C)

The economical option for industrial applications

Technical data:

- Discharge pressure up to 12 bar
- Flow rate up to 1,500 l/h per pump head
- Temperatures from 0 to +80 °C (+60 °C PVC)

Outstanding advantages:

- Suitable for acids and bases
- PTFE-C suitable for Ex zone 1 (II 2 G)



1.4435 (316L) stainless steel pump head

Hygiene-compliant design without compromise

Technical data:

- Discharge pressure up to 20 bar
- Flow rate up to 1,500 l/h per pump head
- Temperatures from -10 to +80 °C

Outstanding advantages:

- Minimum dead spaces
- Optimized working area
- Easy surface cleaning
- Gentle, low-shear fluid metering
- Corrosion resistant
- Wetted parts, Ra < 0.5 µm, electro-polished
- CIP capable
- SIP capable up to 150 °C



Polypropylene pump head

The economical option for hygienic applications

Technical data:

- Discharge pressure up to 6 bar
- Flow rate up to 350 l/h per pump head
- Temperatures from -10 to +60 °C

Outstanding advantages:

- Cost effective design for low pressures
- Minimum dead spaces
- Optimized working area
- Gentle, low-shear fluid metering
- Very good chemical resistance
- Extremely low maintenance effort
- CIP capable
- EPDM* or FFPM* gaskets
- Valve seats made of highly wear resistant PEEK**

* EPDM (ethylene propylene diene monomer): Highly elastic elastomer with good temperature resistance, FFPM (perfluorinated): Chemically highly resistant elastomer with high temperature resistance level

** PEEK (Polyether ether ketone): High-strength plastic with high levels of reverse bending stiffness and very high temperature resistance

For safety and profitability. LEWA ecodos technology.

The LEWA ecodos is a mechanically actuated metering pump with a monitored, 4-layer sandwich diaphragm for low pressures, which has numerous advantages over comparable pumps. The sanitary/hygienic designs are specifically adapted for hygiene-compliant product requirements.

Low-wear valves for a variety of tasks

Operational reliability and service life are decisively dependent on valve quality. The valve design is therefore adapted to the specific application.

Safe and resistant

The 4-layer safety diaphragm made of PTFE consists of two operating diaphragms, one monitoring diaphragm as well as one pressure-resistant safety diaphragm. This ensures that no conveyed fluid leaks; contamination from drive unit oil is impossible. The PTFE material is resistant to nearly all liquids and is highly durable.

The right material for every fluid

Stainless steel is used as a standard material. Material options in the conductive design are PVC-H, PVDF and PTFE. Stainless steel materials 1.4435 (316L) or PP are available for selection for pump heads in the hygienic design.

Diaphragm monitoring system for reliable status indication

The standard diaphragm monitoring system reliably shows the status of the diaphragm. Production can be stopped without danger in any case. The indication is realized via a pressure signal.

Low clearance volume, short dwell time

The clearance volume in the working chamber can be kept low by optimizing the design of the pump head. The fluid flow is designed to ensure the easy execution of flushing and drying procedures.

Hermetically tight

The pump heads are hermetically tight and low-maintenance. The diaphragm drive is sealed off from the drive unit so that no drive unit oil can spill out when replacing the pump head.

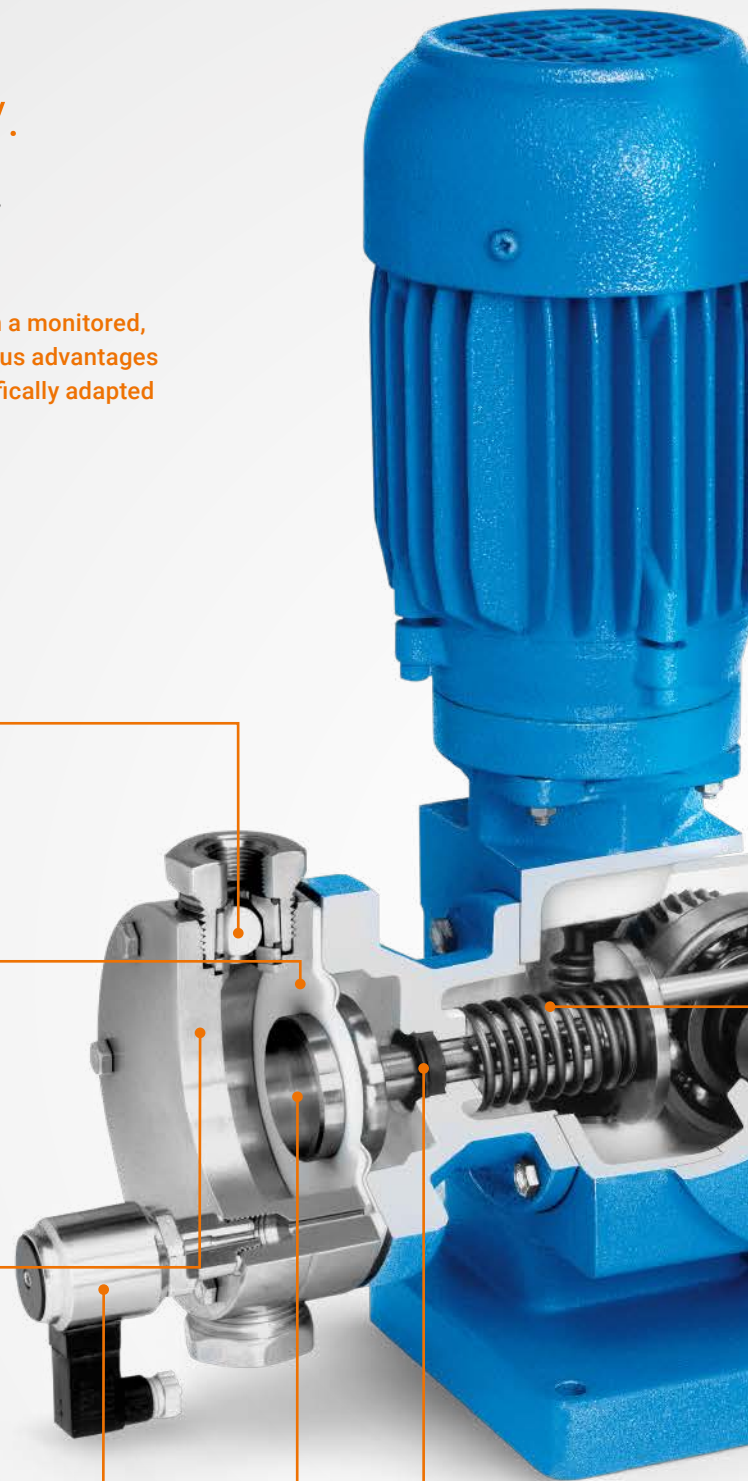



LEWA ecodos

High metering accuracy, gentle conveyance

The metering pumps provide high level of metering accuracy and gentle conveyance, the stroke can be adjusted (manually or electrically) and the stroke frequency can also be adjusted using the frequency inverter. The reproducibility of the adjustments is better than $\pm 1\%$.

Robust drive unit for continuous operation

LEWA ecodos drive units are designed for continuous operation. Spring-cam drive units are used for LEWA ecodos LEB to LEF while variable eccentric drives are used for higher performance.

Aseptic design of piping for quick replacement

Process connections common for the pharmaceutical industry ensure they can be dismantled easily for inspection and maintenance purposes as well as for easy installation.

Optimized sanitary valves for perfect cleaning

Minimum dead space seals on valves ensure optimal cleaning. The gaskets are completely confined and cannot make their way into the product space. This means that all valve components are streamlined and optimized for sterile applications.

Flat surfaces for easy cleaning

All metallic pump head materials consist of 1.4435 (316L) chrome-nickel steel with a delta ferrite content of $< 1\%$. The wetted surfaces are mechanically and electrically polished with a surface quality of $< 0.5 \mu\text{m}$. Due to the highly polished tools, the plastic version also achieves a roughness value R_a of $< 0.5 \mu\text{m}$.

Materials for absolute safety

Only materials that are physiologically harmless are used as wetted materials. The plastics and elastomers used correspond to the FDA requirements and are documented for USP Class VI.

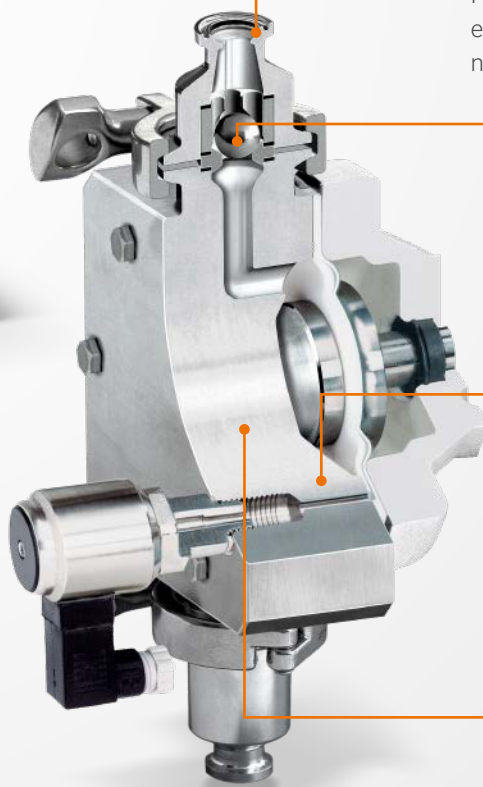

LEWA ecodos hygienic

For the most stringent purity requirements. Sanitary and hygienic design.

The sanitary and hygienic-compliant designs fulfill the requirements for the production of food and pharmaceuticals. The pump heads made of polypropylene or stainless steel are hermetically tight and prevent the pumped product from becoming contaminated. Thanks to its easy-to-clean surfaces, product residue, biological residue and germs can be removed completely.

Benefit to you:

Metering free of contamination

Low dwell volume

Gentle, low-shear metering

Minimum dead spaces

Exact, repeatable metering

Mechanically or electrically polished surfaces

Optimized working area

Aseptic design of piping

CIP/SIP capable

Fulfilling the standard regulations for hygienic processes:



Wetted plastics: FDA-compliant, animal free and documented for USP Class VI

ASME-BPE-compliant (hygienic)

EHEDG EL Class I certified

Available documentation:

Performance test and pressure test

3.1 certificates for all wetted materials

Surface certificates



For the best possible configuration.

Designs, options, accessories overview.

Depending on the desired flow rate and the control range needed, the right rating is selected from the six LEWA ecodos output ratings, or multiple pumps are combined to make a multiplex pump. Different designs are available for pump heads, the metering flow setting, stroke adjustment and speed control. LEWA ecodos can be adapted to a wide variety of jobs with customized control systems as well as a complete line of accessories. The pumps of course meet all of the requirements for integration into automated systems.

Designs

Variable metering flow

Stroke length adjustment using the handwheel or actuator, the stroke frequency using the motor with the frequency inverter or servo drive.

Exact stroke adjustment

- Manual stroke adjustment
- Electric stroke adjustment with stroke length setting and limit-switch shut-off for LEWA ecodos LEB-LEE
- Electric stroke adjustment as well as emergency operation using the handwheel is possible for LEWA ecodos LEG or later with integrated position regulator, guide signal and 4-20 mA (factory setting), optional 0-20 mA
- Without stroke adjustment for the speed control

Precise speed

Expanding the adjustment range using the frequency inverter or servo drive:

- Frequency inverter for engine outputs of 0.37-7.5 kW
- 1-phase or 3-phase device design
- Servo drive with complete control unit

Wide-range speed-controlled metering area

Flow rate Q [l/h]

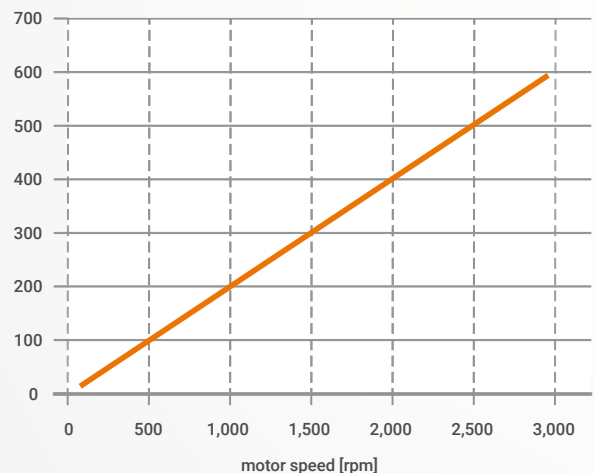

Wide-range speed-control

Possibility to control in a wide speed range of more than 1:100 (up to LEF type). Servo motors or 3-phase motors with speed feedback are used as the drive. Preferred solution for multiplex pumps.

Advantages

- Large adjustment range with only one control variable
- Linear performance curve
- Low pulsation for triplex to hexaplex pumps
- Gentle start possible

Options

Multiplex capability

- Single drive units with vertically installed motor are space-saving
- Multiple drive units with identical or different output can be combined for pulsation reduction or recipe metering

Drives

– Use of IEC motors from renowned manufacturers:

- 3-phase motor 230/400V, 50Hz
- IP55 protection class, isolation class F
- Optional with explosion-proof drives for operation up to zone 1
- Other motors, voltages and protection classes on request

– LEWA Intellidrive

Special solutions can be provided using the highly dynamic servomotor LEWA intellidrive as a drive concept (up to type LEF)

Possibilities:

- Low-pulsation flow rate using wide control range with two or three single pumps
- Controlled individual strokes or partial strokes, e.g. for filling processes; synchronization with higher-level control systems
- Pulsator with modifiable characteristics, e.g. for back flushing filters

Valves

Insert rings for stainless steel pump head valve seats made of:

- PTFE
- FPM
- Polyurethane
- Tempered stainless steel 1.4122 SS

As well as special valves such as cavities being filled for the production of food and pharmaceuticals.

Integration into process control systems

The signal acquisition of process control systems is carried out in an all form. The flow rate can be varied using electrical or pneumatic stroke adjustment, or alternatively by motor speed (frequency converter).

Complete documentation

The documentation is created according to customer specifications, provision of inspection records upon request, pressure samples, pump diagrams and registration papers.

Accessories

- Pulsation damper
- Control and regulation units
- Safety valves
- Pressure retaining valves
- Strainer
- Injection points
- Instrumentation: Contact transmitter attachment on the last drive element as well as determining the number of pump strokes, e.g. for batch metering and balancing.
 - Inductive proximity switch based on NAMUR (DIN19234)
 - Explosion protection Exi
 - IP65 protection

At a glance.

Technical data.

Technical data

Pump type	LEB	LEC	LED	LEE	LEF	LEG
Max. flow rate at 50 Hz [in l/h]	16	52	170	336	520	1,460
Approx. weight (simplex including motor) [in kg]	15	15	23	30	60	76

LEWA ecodos/LEWA ecodos sanitary

Pump head made of stainless steel

Operating pressure [in bar]	20	10	10	7.5	7.5	5
Max. operating temperature [in °C]	-10/+80					
Valve type	Ball					Ball/plate
Standard connections	G3/8" IG		G1/2" IG		DN25 PN40 flanges	
Connections (optional)	Sanitary connection, Triclamp, DIN + ANSI flanges					

Pump head made of PVC-H

Operating pressure [in bar]	12	10	10	7.5	7.5	5
Max. operating temperature [in °C]	0/+60					
Valve type	Ball					Ball/plate*
Standard connections	Hose/socket Ø 12		Hose/socket Ø 20		DN25 PN40 flanges	
Connections (optional)	DIN + ANSI flanges					

Pump head made of PVDF fluoroplastic

Operating pressure [in bar]	12	10	10	7.5	7.5	5
Max. operating temperature [in °C]	-10/+80					
Valve type	Ball					Ball/plate*
Standard connections	G3/8" IG		Hose/socket Ø 20		DN25 PN40 flanges	
Connections (optional)	DIN + ANSI flanges					

LEWA ecodos hygienic

1.4435 (316L) stainless steel pump head

Operating pressure [in bar]	20	10	10	7.5	7.5	5
Max. operating temperature [in °C]	-10/+80					
Valve type	Ball					Ball/plate
Standard connection [Triclamp]	1/4"	1/2"	3/4"		1"	
Connections (optional)	Sterile connections, e.g. in accordance with DIN 11864					

Polypropylene pump head (PP)

Operating pressure [in bar]	-	6	6	6	-	-
Max. operating temperature [in °C]	-	-10/+60			-	-
Valve type	-	Ball			-	-
Standard connection [Triclamp]	-	1/2"	3/4"		-	-

Sandwich diaphragm made of PTFE
 Ceramic oxide ball valves, Gylon or PTFE seal rings
 Stainless steel design: Ball valves with 316L ball, PTFE seal rings
 PP design: Ball valve with ceramic oxide ball, EPDM seal rings, optional FFP
 * Valve springs made of Hastelloy
 IG = internal thread

Installation dimensions

	L in mm	W in mm	ΔW in mm	H in mm
LEB/LEC	360	220	85	480
LED/LEE	425	220	120	570
LEF	595	270	175	660
LEG ¹⁾	500	400	–	800
LEG ²⁾	500	900	250	450

1) Vertical motor installation
2) Horizontal motor installation

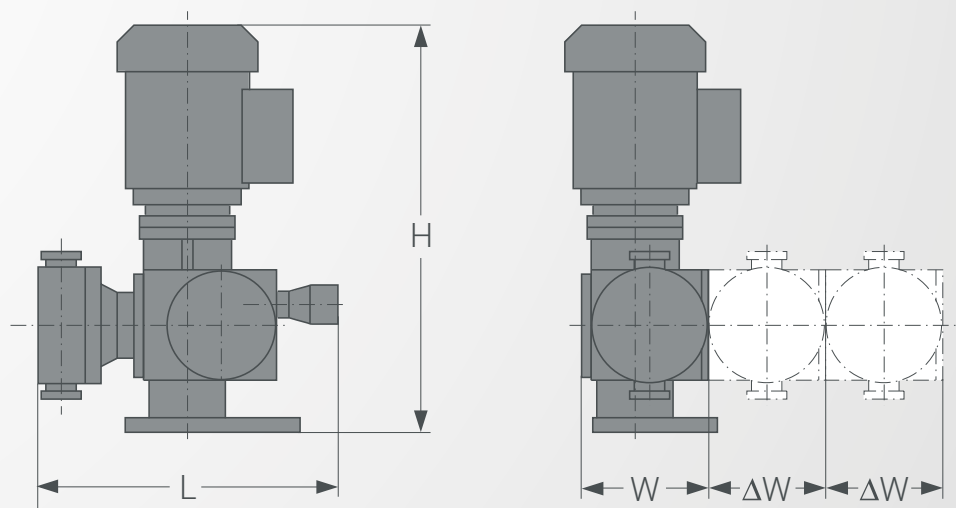

Save space and weight through multiplex arrangement of pumps.
Meter multiple liquids at the same time with various pump heads.

Complete solutions from a single source. LEWA packages and systems.

LEWA also offers solutions that go beyond individual process or metering pumps. For decades, we have built customer-specific systems, skids, and packages. Our service ranges from engineering to commissioning – including custom system controllers, process visualization, operational data collection, and external interfaces to the process control system.

We guarantee optimal implementation of your requirements thanks to our knowledge and skills in smart process control and the control and regulation technology it requires.

The basis is the competent selection and combination of system components and their characteristics. The core component of LEWA packages and systems is a process pump.



Each process has specific requirements. LEWA's experts tailor all components carefully to each other and bring in valuable industry know-how.



Creating Fluid Solutions. For more value created.



Technical consulting

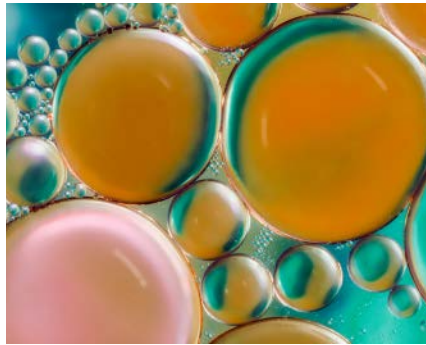

Fluid and process engineering tests



Lifecycle concepts and energy optimization

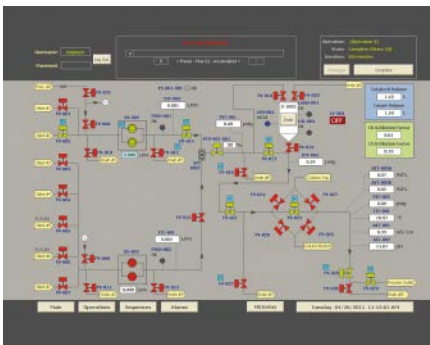

Process automation



Pulsation studies and pipeline calculations



System layout and integration



Creative development and refinements



Commissioning and maintenance service



Spare part and service concepts

Creating Fluid Solutions.

Driven by our commitment, our trendsetting products and innovative technologies have set benchmarks for diaphragm pumps, process pumps and metering systems for over 70 years. We solve complex tasks from a single source. That ranges from custom pump design, basic and system engineering, global project management, and pretesting to commissioning and maintenance on site. Our consistent drive always to develop the best solutions for the customer provides you with a competitive advantage and visible added value.

LEWA GmbH

Ulmer Str. 10
71229 Leonberg
Germany

www.lewa.com

■ Part of Atlas Copco Group

